

# Lindab **RoofSafetySystem**

















Installation instructions

# Contents - guide





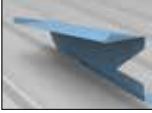

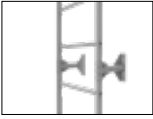

## Formal requirements

Laws and regulations

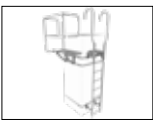
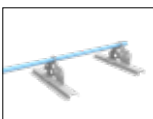
## Fastening for roofs

Concrete tile with batten underlay		7	SRP25/SRP25N Seam roof profile		20
Concrete tile with light underlay		8	Tile roofing on batten underlay		22
Standing seam long strip roofing		9	Tile roofing on light underlay		23
Fibre cement roof		10	Trapezoidal profile 115		24
Lindab tile (LPA, LPE)		11	Trapezoidal profiled steel sheet		25
Steel sheet LPP 20		12	Pivot bolt		26
Felt roofing on batten underlay <i>TATPLAT felt mechanical attachment</i>		13			
Felt/membrane externally insulated high profile <i>TATPLAT mechanical attachment</i>		14			
Felt/membrane fastening on the exterior only <i>YTPLAT steel liner</i>		16			
Sandwich panels		18			
Sinusoidal profiled steel sheet		19			

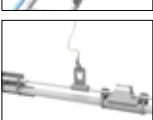
## Assembly of protective device

.....		.....
Façade ladder		27
.....		.....
Slide protection		31
.....		.....
Chimney ladder		34
.....		.....
Ridge rail		35
.....		.....
Snow guard		36
.....		.....
Guard rail		40
.....		.....
Roof walkway		42
.....		.....
Roof ladder		48
.....		.....
Wire system		54
.....		.....
Anchorage poin		59

### Installation requirements

For fastening to your rooftype see chapter "*fastening for roofs*", then go forward to your product "*assembly of protective device*" to complete your montage.

# Formal requirements in Sweden

## Before you start

The roof is the workplace for many different categories of profession. Tinsmiths, chimney sweeps and caretakers work on rooftops daily in rain, snow and windy weather.

Lindab has developed a full range of roof safety products for all professional groups that work on roofs.

Learn which rules and regulations apply for the relevant application

## Regulations

The Swedish National Board of Housing, Building and Planning building regulations BRR 2008 (with some exceptions) apply from 1 July 2008. All products are tested according to the applicable test standards and fulfil the requirements for the relevant functional standard.

Façade height	0-3 m		3-4 m			4-8 m			>8m		
	<1:10 <5.7°	>1:10 >5.7°	<1:10 <5.7°	>1:10 >5.7°	>1:3 >18.3°	<1:10 <5.7°	1:10- 1:3 5.7°- 18.3°	>1:3 >18.3°	<1:10 <5.7°	1:10- 1:3 5.7°- 18.3°	>1:3 >18.3°
Slide protection for portable ladder BBR 8:2421											
Fixed wall ladder with fall protection, or interior ascent BBR 8:2421											
Only interior ascent BBR 8:2421											
Guard rails by ascent openings BBR 8:2421											
A fixed roof ladder and/or walkways to the ridge, chimney or workplace BBR 8:2422											
Walkway along the entire roof ridge BBR 8:2422											
Eyelets for safety lines BBR 8:2431											
Fixing device for safety line, e.g. ridge rails or walkway BBR 8:2431											
Footrest at the roof pitch and eaves BBR 8:2432											
Protection against falling ice and snow at the entrances to buildings BBR 8:2434											
Guard rail around surfaces that may be walked on by mistake and cannot bear a person's weight BBR 8:2433											

Requirements apply for shaded fields

### **Fixed work stations**

*BBR 8:2423*

Fixed work stations must be designed in consideration of the total fall height, the type of work and the risks arising when the work is carried out. Fixed work stations requiring period maintenance should have an accessible area of at least 0.30 x 0.60 m. It can be a horizontal surface on the crown of the chimney or a platform that is at most 0.5 m below the crown. Guard rails should be at least 1.0 m high and have a hand rail on the upper edge and at half of the rail height.

### **Moving on the roof**

*BBR 8:2422*

Chimneys should be provided with an ascending device if the chimney height is greater than 1.2 m at the place of ascension. If the fall height is greater than 4 m from the work station to the surface below that prevents a continued fall, the ascending device should be provided with fall protection.

### **Fire protection regulations**

Fire protection should be designed in accordance with BBR 5:374 2002. Lindab's roof safety product range fulfils applicable requirements for escape routes.

### **Snow guard**

Chapter 3 of the Swedish Public Order Act 1993:1617 is the set of regulations stipulating where snow guards must be installed. BBR 2008 is considered complementary to this.

§3

Snow and ice that can fall down and injure people or property in public locations\* must be removed promptly from roofs, gutters and similar equipment without unreasonable delay. This shall take place in a manner such that it does

not pose a risk of personal injury or property damage. The responsibility for ensuring that the appropriate measures take place is incumbent on the owner or the party assuming the owner's place as a result of a contract for use or similar reason.

\* According to this law, the following apply as public locations: 1 public roads, 2 streets, roads, squares, parks and other places that are identified as public areas in local detailed plans and have been designated for this purpose, 3 areas that are identified in local detailed plans as a development district for port activities, if they have been designated for this purpose and are accessible to the general public, and 4 other land areas and spaces indoors that are used permanently for public traffic.

### **The Swedish Work Environment Act**

A risk analysis according to the Swedish Work Environment Authority statutes AFS 1999:3 and AFS 1981:14. This can also entail that a controller and/or inspection person stipulates additional roof safety. A risk analysis gives consideration to special risks on specific buildings and the type of work. In this case, the Work Environment Act always takes priority. BBR 2008 specified minimum requirements for all buildings in general.



# Concrete tiles with batten underlay

## Installation requirements

Wood: min. 19 mm  
Plywood: min. 15 mm

Refer to the installation instructions for the safety equipment for the number of brackets.

## Fixing of KOUND on tongue and groove or plywood underlay

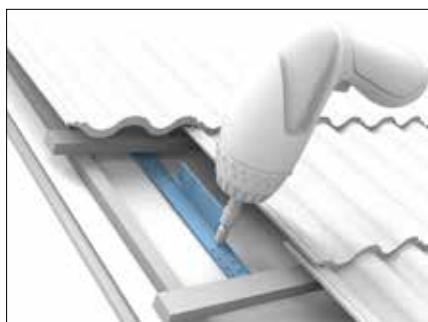

Install KOUND between battens in the desired place fix on the underlay with the eight accompanying screws from bolt set 20.



Lay KOBET/L (concrete tile) on the upper bracket and let it rest on the tiles. Fix in place with the two drill bit screws from bolt set 20 - one on each side of the bracket.

Step 2 can take place on the ground to facilitate installation. Then you have to use the first bracket to determine which hole pattern is optimal for the pitch.

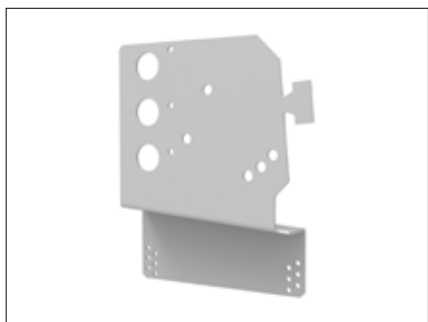

KOBET can be used for installation of all protective equipment except ladder: roof walkway, guard, and ROR snow guard.



KOBETL can be used for installation of all protective equipment except for roof walkways and ladder: e.g. guards and ROR snow guard.

# Concrete tiles with light underlay

## Installation requirements

Min. 45x70 batten.

Refer to the installation instructions for the safety equipment for the number of brackets.

### Fastening of KLF on battens for light underlay



Fit KLF supporting bracket on the batten and fasten in place with the four accompanying screws from bolt set 21 where they fit against the batten - two in the upper and two in the lower batten.



Lay KOBET/L (concrete tile) on the upper bracket and let it rest on the tiles. Fix in place with the two drill bit screws from bolt set 21- one on each side of the bracket.

Step 2 can take place on the ground to facilitate installation. Then you have to use the first bracket to determine which hole pattern is optimal for the pitch.

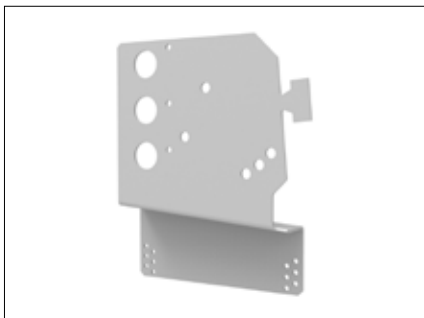

KOBET can be used for installation of all protective equipment except roof ladder: roof walkway, guard, and ROR snow guard.

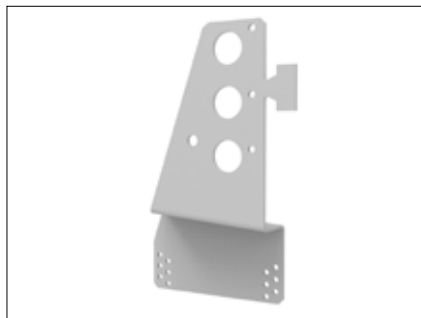

KOBETL can be used for installation of all protective equipment except for roof walkways or ladder: e.g. guards and ROR snow guard

# Standing seam long strip roofing

## Installation requirements

Steel sheet: min.  $d = 0.6$  mm double-folded seam

Titanium zinc: min.  $d = 0.7$  mm double-folded seam

Copper sheet:  $d = 0.6$  mm double-folded seam

Aluminium sheet min.  $0.8$  mm double-folded seam.

FFIP insulation profile is used for installation on a copper roof.

UNIK bracket is available fully assembled on FF seam fastener. This component is called FFUNIK.

## Fastening of FF seam fastener on standing seam long strip roofing

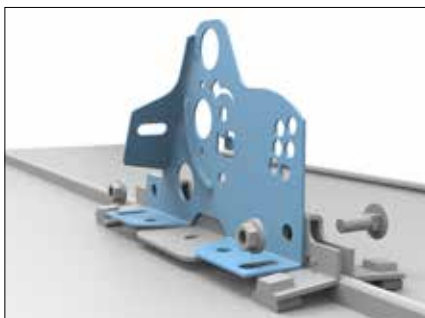

For installation with UNIK (snow guard, walkway, etc.), mount the bracket at the same time of the FF seam fastener. Ensure that the FF seam fastener's heels rests on the roof. Tighten the bolts to 20 Nm.

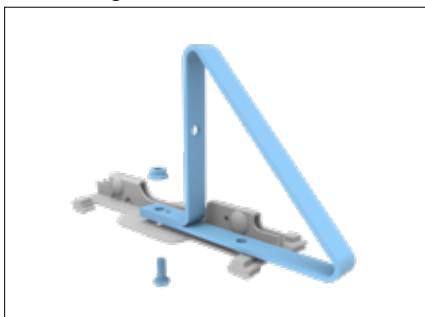

If the HSN bracket is used (snow guard), fit it on the FF first, as illustrated. Mount HSN on FF with 1 screw and nut from bolt set 4.

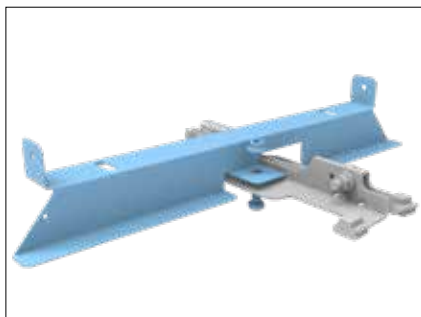

If the TSKFF bracket is used (roof ladder or walkway), mount it on the FF first, as illustrated. Mount TSKFF on FF with 1 screw and bolt from bolt set 36.

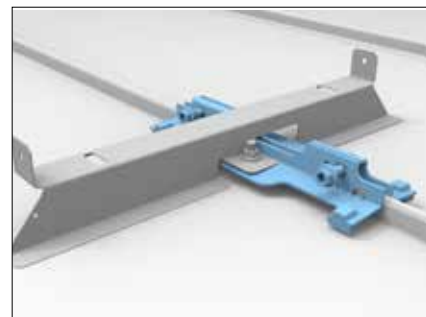

Mount FF seam fastener around the steel panel seam. Ensure that the FF seam fastener's heels rest on the steel panel. Tighten the bolts to 20 Nm.

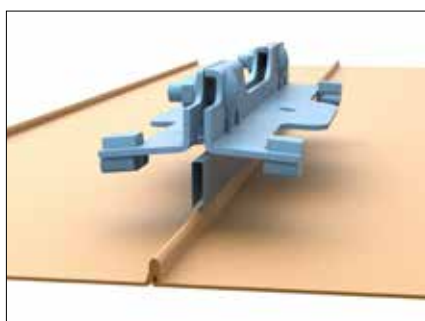

When mounting on copper roofs, insulation profile FFIP is used to prevent corrosion between FF and the copper roof.

# Fibre cement roof

## Installation requirements

Batten distance:  
CELUF is intended for a batten distance of 535 mm.

With a distance of 1070 mm, you need to install an extra batten.

## Fastening of CELUF

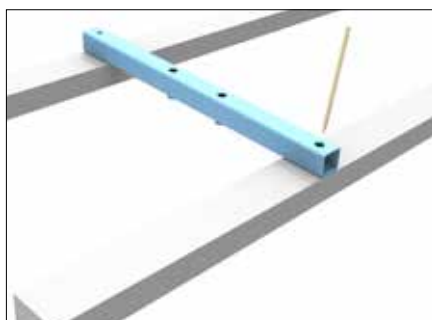

Position the CELUF parallel with the panel corrugation. The CELUF height should be at the same height on the batten (A). Mark the locations to drill holes in the batten.



Drill with a  $\varnothing$  11-12 mm drill bit.

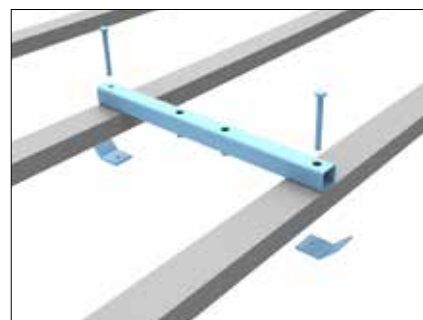

Screw CELUF in the batten firmly and mount the roof panel.

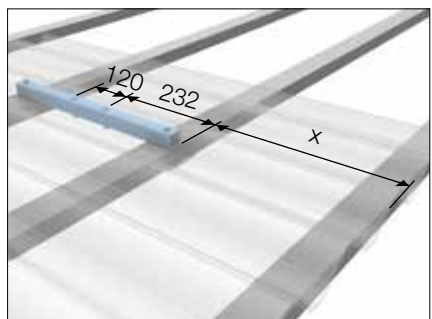

Then measure the distance  $x$  from the lower edge of the roof panel to the lower edge of CELUF. Add 232 mm and then mark the hole for the supporting tubes. Mark 120 mm higher up for the other hole.

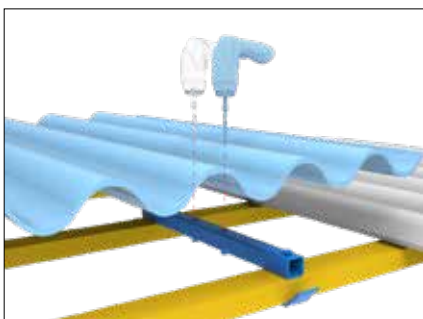

Drill with a  $\varnothing$  20 mm carbide drill bit and lower the supporting tubes in the fastener.

## Centre-to-centre distance to the next fastener

Snow zone	Medio P6	Cembonite
1	1062	1176
1.5	1062	1029
2	885	882
2.5	885	882
3	708	735
4	708	588

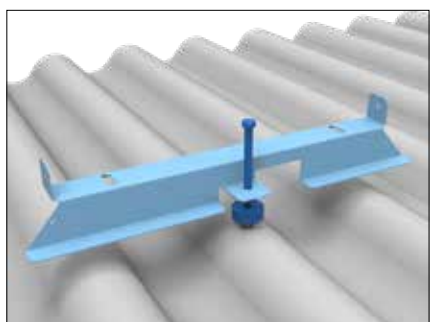

For mounting of roof ladder use TSKFF.

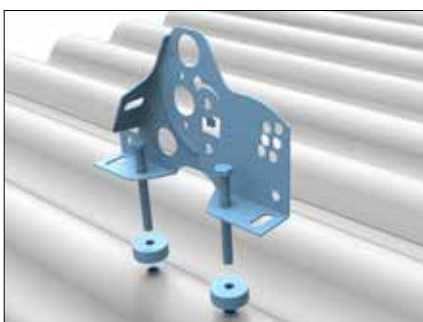

Mounting of console UNIK.

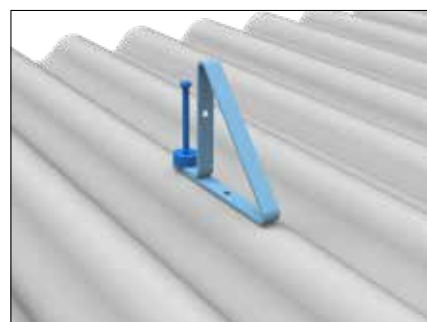

For mounting of snow fence SNO use HSN.

# Lindab tile

## Installation requirements

Steel sheet: min. d = 0.5 mm

The installation takes place entirely from the roof's exterior.

## Fastening of IFLPA, IFLPE fastening plate.

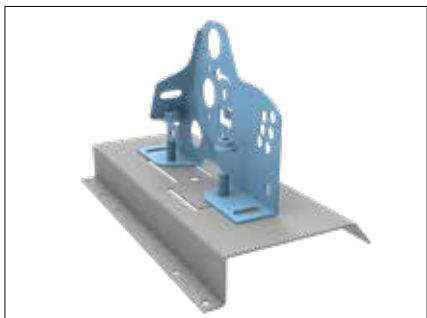

For installation with UNIK (snow guard, walkway, etc.) assemble UNIK at the same time as IFLPA/IFLPE with 2 screws, washer and nut from bolt set 29.



Position IFLPA/IFLPE in the desired location on the roof. Fix it in place with the ten accompanying point screws from bolt set 29.

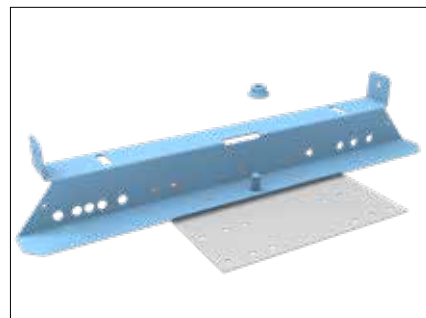

If TSK is used (roof ladder or walkway), mount it on TSKIF first, as illustrated. Mount TSK on TSKIF with 1 screw and nut from bolt set 2, without tightening the nut.

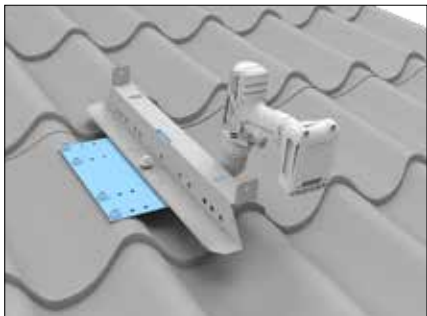

Position TSKIF on a profile top on the plate at least 200 mm from the edge of the plate. Fasten TSKIF with the eight accompanying point screws from bolt set 2.

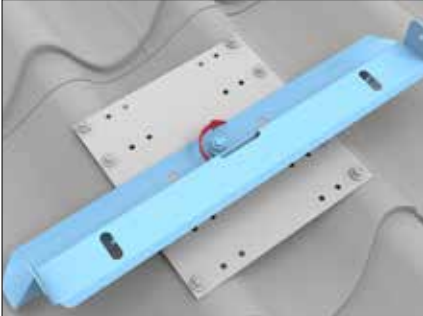

Finally tighten the nut for fastening TSK on TSKIF.

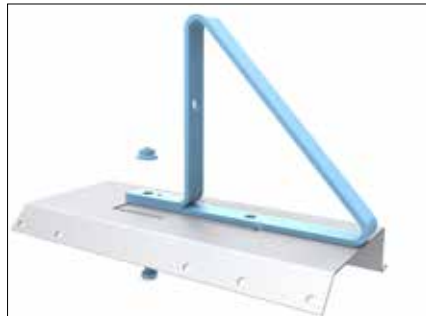

If HSN is used (with SNO), mount it on IFLPA/IFLPE first, as illustrated. Mount HSN with 1 screw and nut from bolt set 29.

# Boiler plate LPP20

## Installation requirements

Steel plate min. 0.5 mm

### Fastening of IFLPP

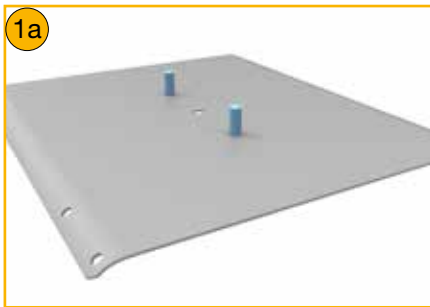

Install carriage bolts on IFLPP from underneath for UNIK from bolt set 23.

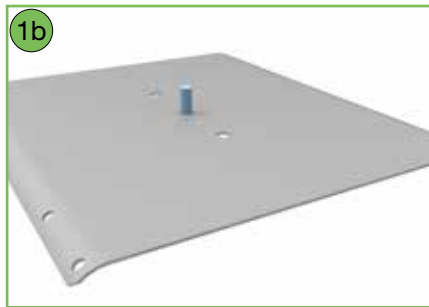

Mount carriage bolt on IFLPP from underneath for TSK or HSN from bolt set 23.



Mount UNIK in the bolts.



Mount TSK in the bolt.



Mount HSN in the bolt.

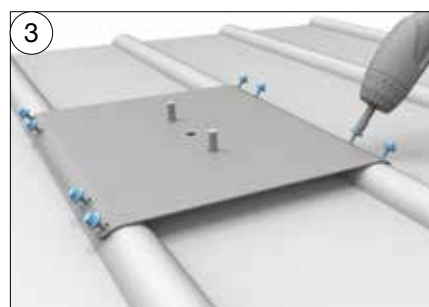

Position IFLPP on LPP20 and fasten in the plate with eight point screws from bolt set 23.

# Felt roofing on batten underlay

## Mechanical fastening with TATPLAT/L PAPP fastening plate

### Installation requirements

Installation - fastening device for roofs with tongue-in-groove board and TATPLAT/L PAPP waterproofing.

Approved regardless of waterproofing type

Tongue-in-groove board minimum 19 mm

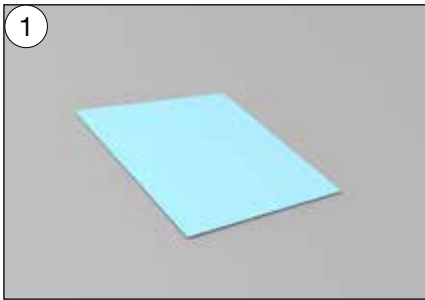

1 Cut a 500 x 600 mm rectangle of felt for application on the roof. Position it where the seal plate will be mounted with the bottom side facing up.

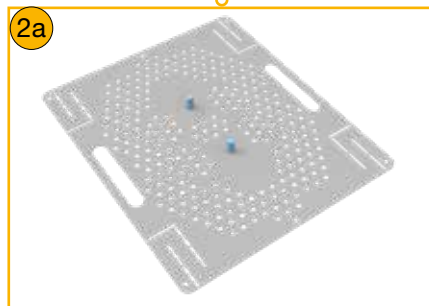

2a Install the carriage bolts from bolt set 26 in the TATPLAT from underneath. For UNIK.

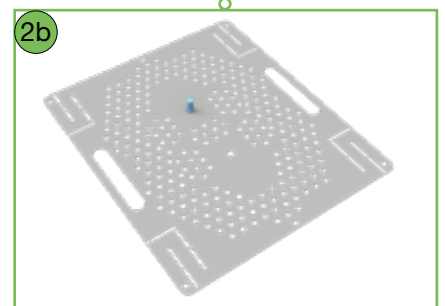

2b Install the carriage bolt in the TATPLAT/L from underneath. For TSK from bolt set 26 or for LLF150 from bolt set 27.

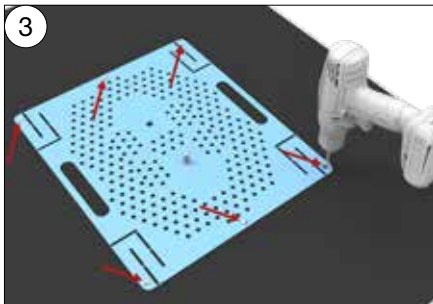

3 Position TATPLAT/L on the felt rectangle and fasten the 6 accompanying screws from; bolt set 26 TATPLAT, bolt set 27 TATPLATL.



4 Position the felt and make holes for the bolt or bolts through the waterproofing layer. Heat the roof felt so that it melts together with the underlying felt rectangle through the perforation.

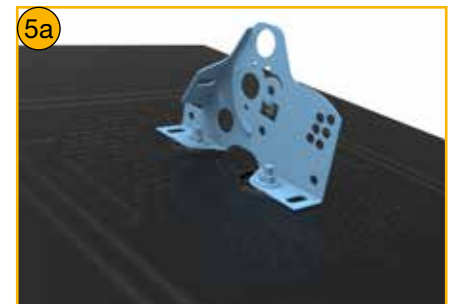

5a Mount UNIK on TATPLAT. Use the accompanying GRB rubber disc under the fastener and the accompanying nuts from bolt set 26.

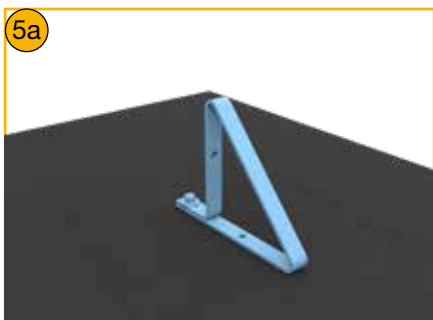

5a Mount HSN on TATPLAT. Use the accompanying GRB rubber disc under the fastener and the accompanying nut from bolt set 26.

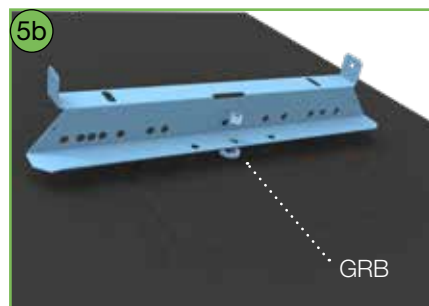

5b Mount TSK on TATPLAT. Use the accompanying GRB rubber disc under the fastener and the accompanying nut from bolt set 26.

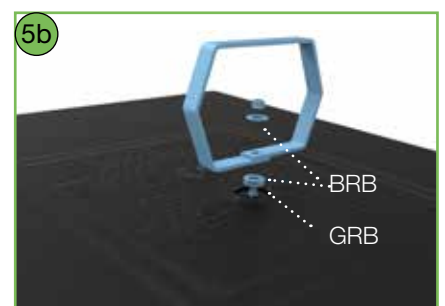

5b Mount LLF150 on TATPLATL. Use the accompanying GRB rubber disc under the fastener and the accompanying nut. A disc must also be arranged above the rubber disc for LLF150. Use bolt set 27.

# Felt/membrane roof externally insulated decking - *new roof*

## Installation requirements

Fastening devices for roofs with external insulation with membrane covering

For installation on LHP115

Approved regardless of waterproofing type

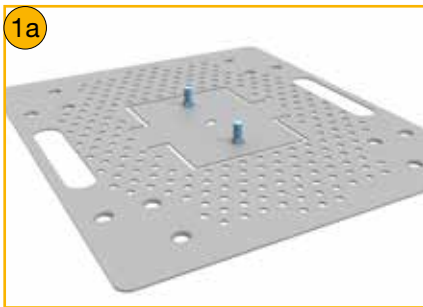

1a Install carriage bolts in TATPLAT from underneath. For UNIK.

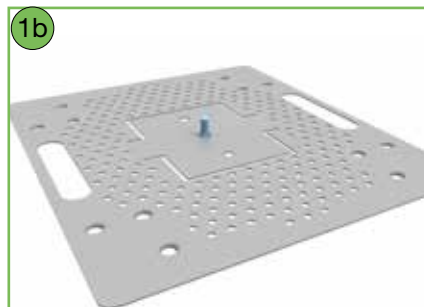

1b Install the carriage bolt in the TATPLAT/L from underneath, from bolt set 26 for bracket TSK or bolt set 27 for LLF150.

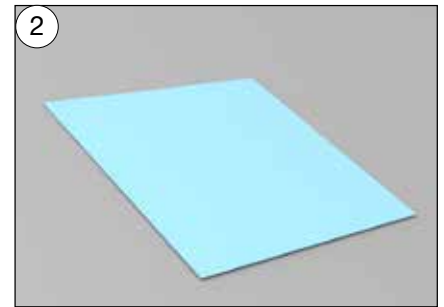

2 Cut a minimum 800 x 900 mm rectangle of the membrane to be arranged on the roof. Position it where TATPLAT/L should be installed with the bottom facing up.

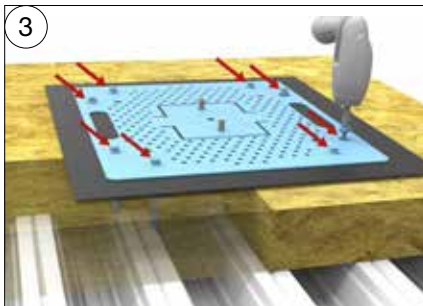

3 Position TATPLAT/L in the desired location and find the underlying crest in the plate. Push in the accompanying sleeves. 2 x in each corner, 8 in total. Fasten them with the accompanying screws.

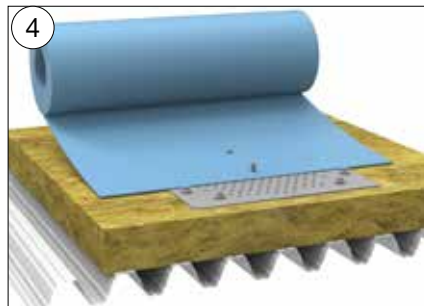

4 Apply the roof membrane on the roof surface according to the applicable regulations. Make holes for bolt/bolts.

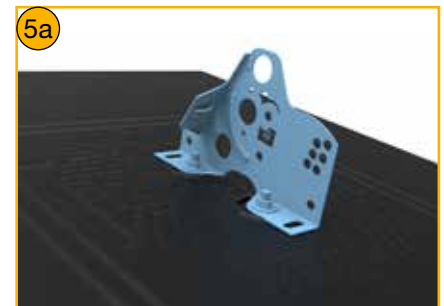

5a Mount UNIK on TATPLAT. Use the accompanying GRB disc under UNIK and the accompanying nuts.

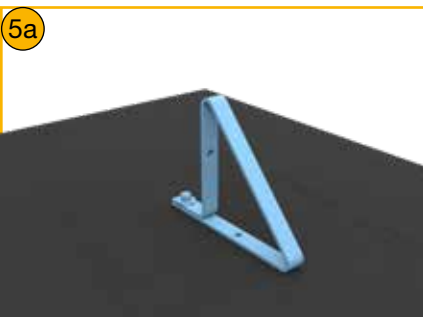

5a Mount HSN on TATPLAT. Use the accompanying GRB rubber disc under the fastener and the accompanying nut from bolt set 26.

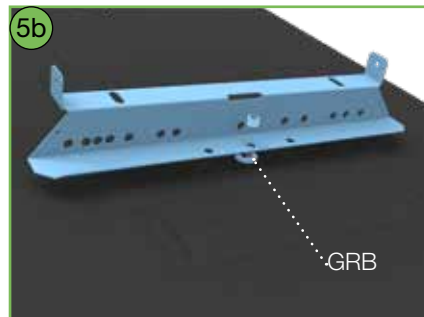

5b Mount TSK on TATPLAT. Use the accompanying rubber disc GRB under TSK and the accompanying nuts.

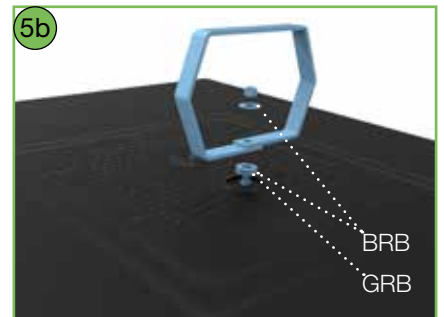

5b Mount LLF150 on TATPLAT. Use the accompanying rubber disc GRB under LLF150 and the accompanying nuts. There should also be a disc above the rubber disc.

# Felt/membrane roof externally insulated decking - *existing roof*

## Installation requirements

Fastening devices for roofs with external insulation with membrane covering

For installation on LHP115

Approved regardless of waterproofing type

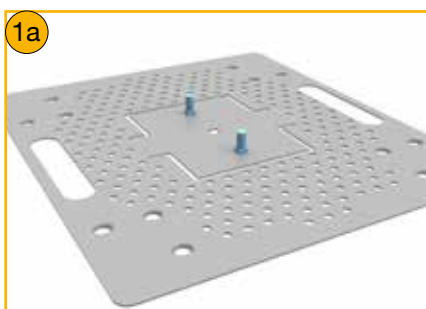

1a Install the carriage bolts in the TATPLAT from underneath. For UNIK.

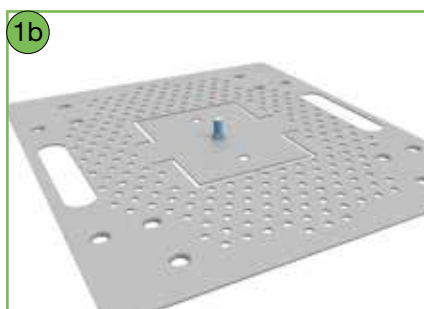

1b Install the carriage bolt/bolts in the TATPLAT from underneath. For bracket TSK or LLF150.

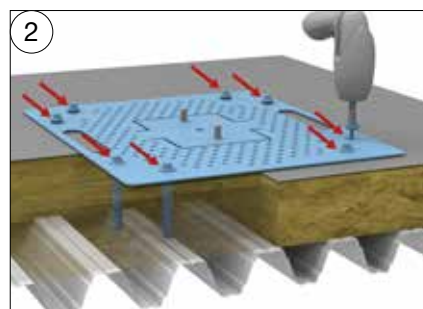

2 Position TATPLAT/L in the desired location and find the underlying crest in the plate. Push in the accompanying sleeves. 2 x in each corner, 8 in total. Fasten them with the accompanying screws.



3 Cut a minimum 800 x 900 mm rectangle of the membrane.

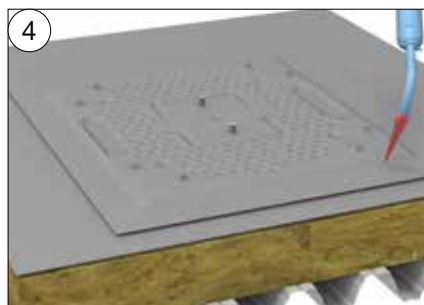

4 Apply the roof membrane on the roof surface according to the applicable regulations. Make holes for bolt/bolts.

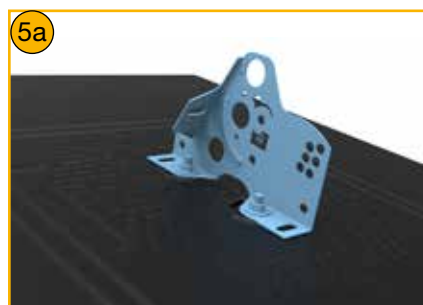

5a Mount UNIK on TATPLAT. Use the accompanying GRB disc under UNIK and the accompanying nuts.

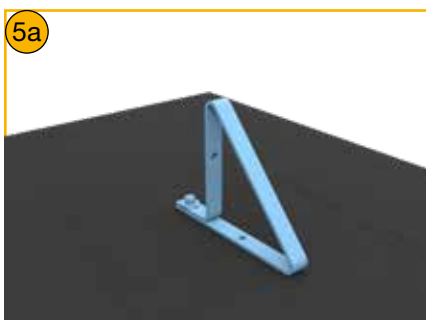

5a Mount HSN on TATPLAT. Use the accompanying GRB rubber disc under the fastener and the accompanying nut from bolt set 26.

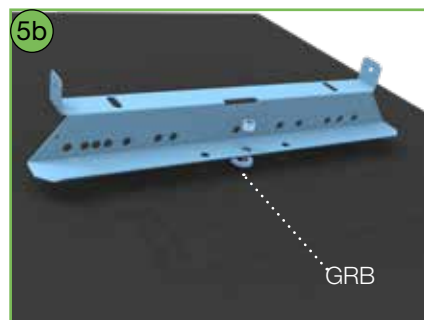

5b Mount TSK on TATPLAT. Use the accompanying rubber disc GRB under TSK and the accompanying nuts.

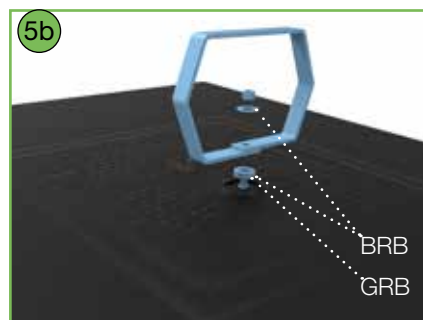

5b Mount LLF150 on TATPLAT. Use the accompanying rubber disc GRB under LLF150 and the accompanying nuts. There should also be a disc above the rubber disc.

# Felt/membrane fastening on the exterior - *new roof*

## Installation requirements

Roof membrane made of PVC, ECB or FPO. Min. thickness 1.2 mm.

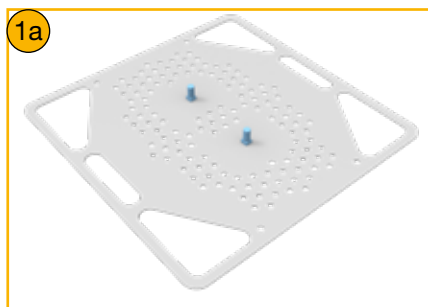

1a Install carriage bolts on YTPLAT for UNIK from underneath, from bolt set 3 or 30.

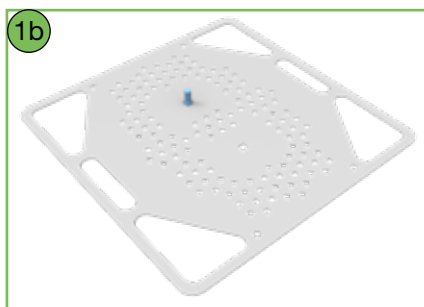

1b Mount carriage bolt on YTPLAT for TSK or HSN from underneath from bolt set

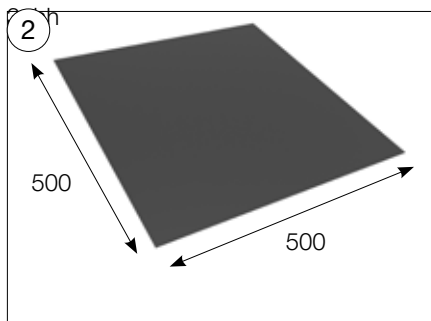

2 Cut a minimum 500 x 500 mm underlay of the membrane.

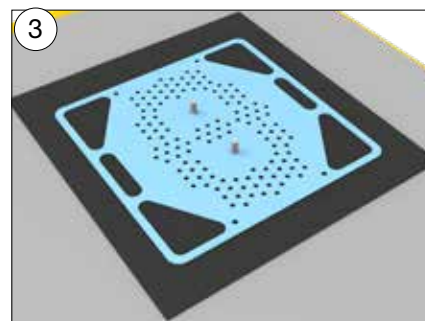

3 Position YTPLAT in the centre of the underlay.

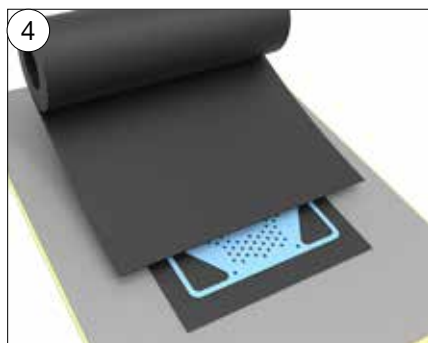

4 Position the exterior mat and make holes for the bolt or bolts.

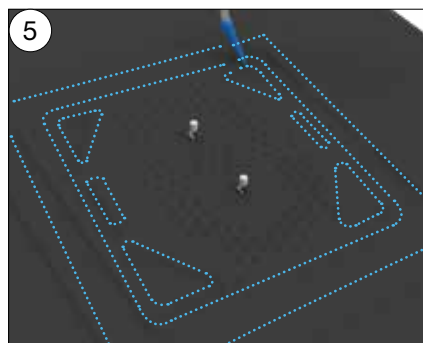

5 Heat the roof felt so that the exterior mat melts together with the underlying felt rectangle through the perforation.



6a Mount UNIK on YTPLAT. Apply the accompanying GRB disc under UNIK and the accompanying nuts from bolt set 3.

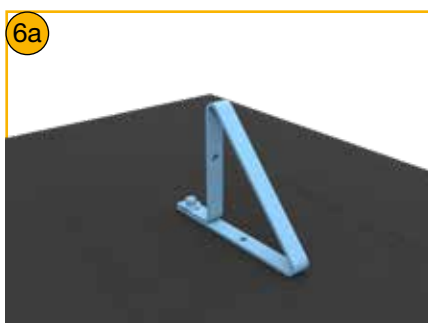

6a Mount HSN on TATPLAT. Use the accompanying GRB rubber disc under the fastener and the accompanying nut from bolt set 26.

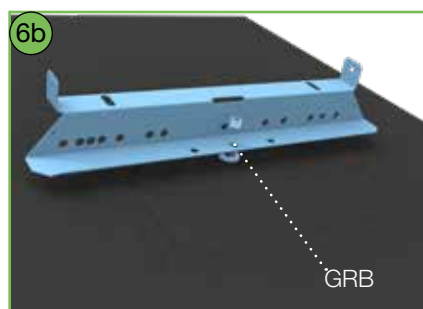

6b Mount TSK on YTPLAT. Apply the accompanying rubber disc GRB under TSK and the accompanying nuts from bolt set 3.

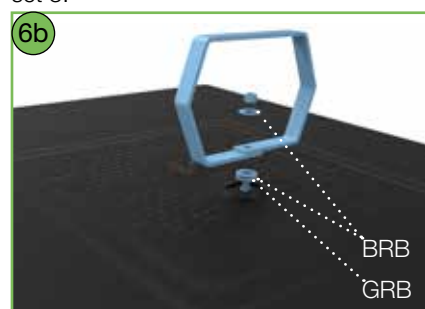

6b Mount LLF150 on YTPLAT. Apply the accompanying rubber disc GRB under LLF150 and the accompanying nuts from bolt set 30. There should also be a disc above the rubber disc.

# Felt/membrane fastening on the exterior - *existing roof*

## Installation requirements

Roof membrane made of PVC, ECB or FPO. Min. thickness 1.2 mm.

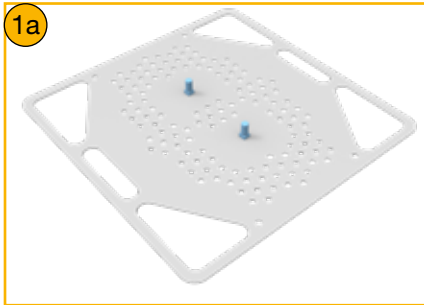

1a Install carriage bolts on YTPLAT for UNIK from underneath from bolt set 3 or boltset 30.

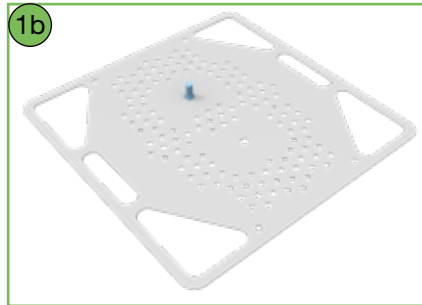

1b Mount carriage bolt on YTPLAT for TSK or HSN from underneath from bolt set 3.

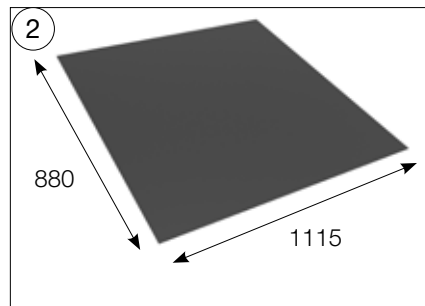

2 Cut a minimum 1115 x 880 mm underlay of the membrane.

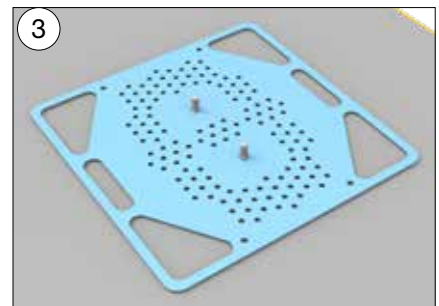

3 Heat the exterior layer and position YTPLAT in the desired location with the desired number of bolts.

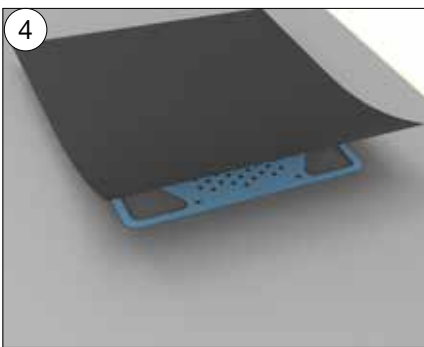

4 Make holes in the underlay membrane and position it over the fastening.

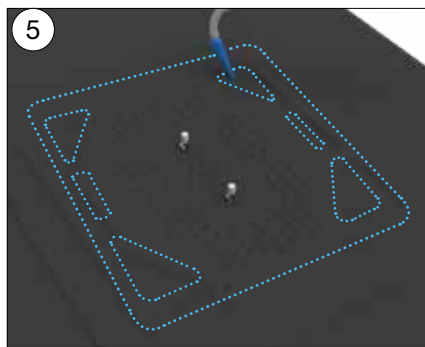

5 Seal the entire surface.

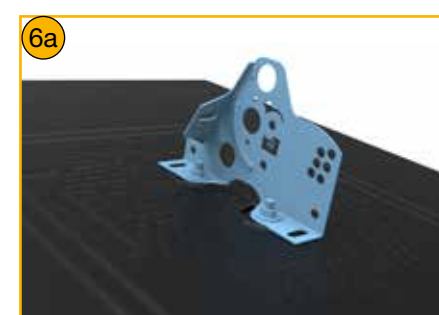

6a Mount UNIK on YTPLAT. Use the accompanying GRB disc under UNIK and the accompanying nuts from bolt set 3.

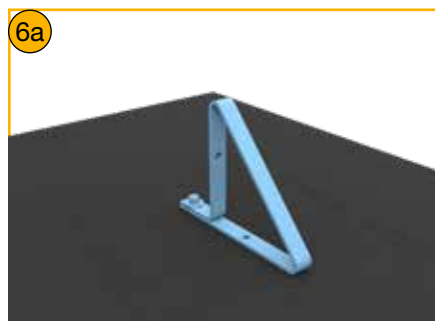

6a Mount HSN on TATPLAT. Use the accompanying GRB rubber disc under the fastener and the accompanying nut from bolt set 26.

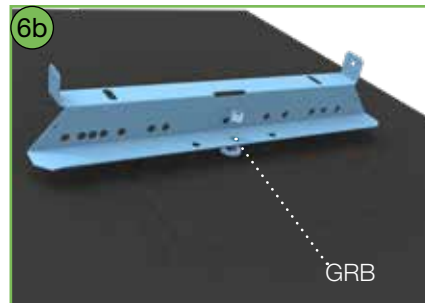

6b Mount TSK on YTPLAT. Use the accompanying rubber disc GRB under TSK and the accompanying nut from bolt set 3.

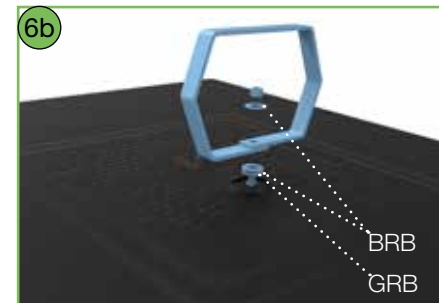

6b Mount LLF150 on YTPLAT. Use the accompanying rubber disc GRB under LLF150 and the accompanying nut from bolt set 3. There should also be a disc above the rubber disc.

# Sandwich panels

## Installation requirements

Min. exterior plate thickness: 0.5 mm steel plate.

Profile provided for pitch of 7°-13° and 14°-21°

### Fastening of SAWBRK (for roof walkway)

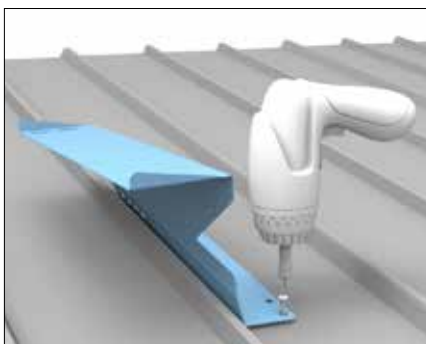

Mount SAWBRK on the sandwich panel  
Use the 10 accompanying screws from bolt set 9.

### Fastening of ladder bracket TSKL (for roof ladder)

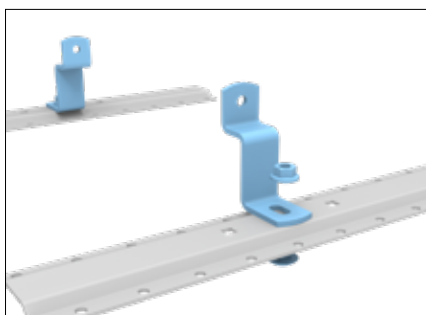

Install the bracket TSKL on SAWPLF.  
Use the accompanying screws from bolt set 11. The nuts are positioned on the upper side.

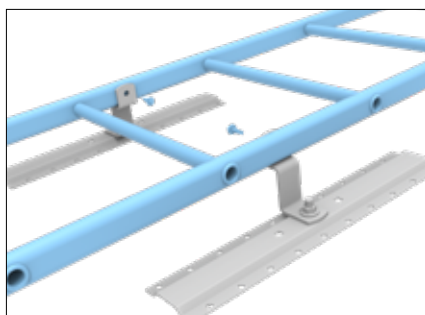

Mount two TSKL + SAWPLF on each side of the top of the ladder. Mount with one screw and nut on each side accompanying TSKL.



Install the top of the ladder by fastening SAWPLF on the roof panel. Use the 8 accompanying screws from bolt set 11.

### Fastening of SAWK and SAWPLF (for ridge rail and snow guard ROR).

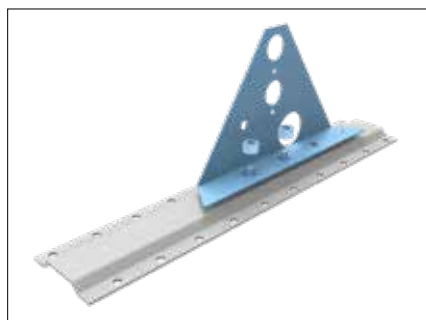

Install SAWK on SAWPLF. Use the 2 screws and nuts from bolt set 11. The nuts are positioned on the upper side.

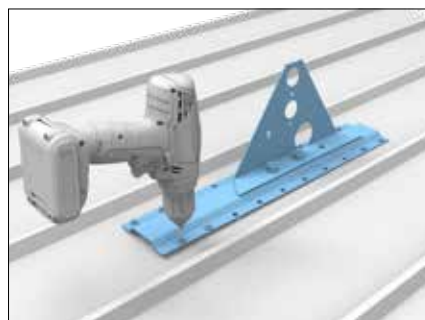

Mount SAWPLF on the sandwich panel. Use the eight accompanying screws from bolt set 11. Use the outer holes on SAWPLF.

### Fastening wall ladder

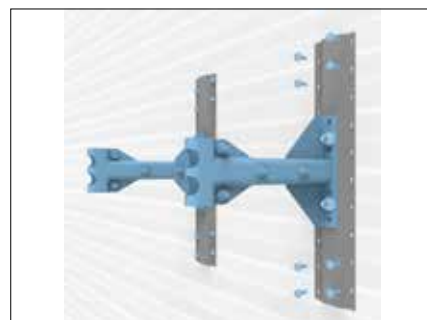

Mount console VSK on SAWPLF with 2 screws and nuts from bolt set 11, nuts positioned on the upper side. Mount SAWPLF on the sandwich panel with 8 screws from bolt set 11.

# Sinusoidal profiled steel sheet

## Installation requirements

Steel sheet: min. d = 0.5 mm

The installation takes place entirely from the roof's exterior.

## Fastening of IFSIN 26

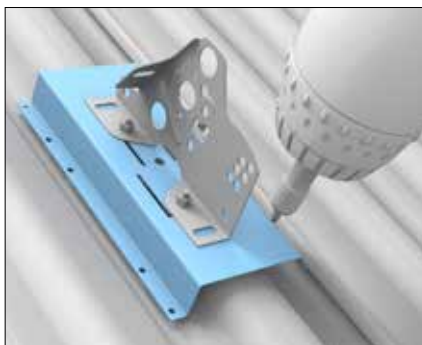
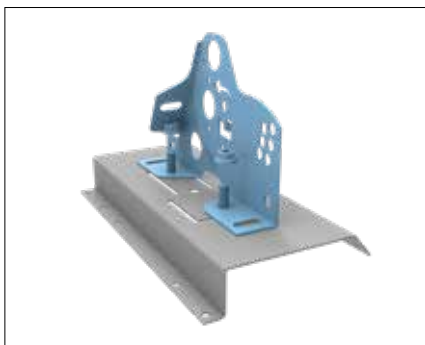

For installation with UNIK (snow guard, walkway, etc.) assemble UNIK on IFSIN 26. Mount with 2 screws and nuts from bolt set 29, nuts positioned on the upper side.

Position IFSIN 26 in the desired location on the roof. Fix it in place with ten screws from bolt set 29.

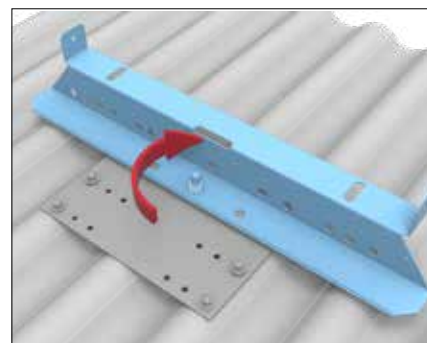
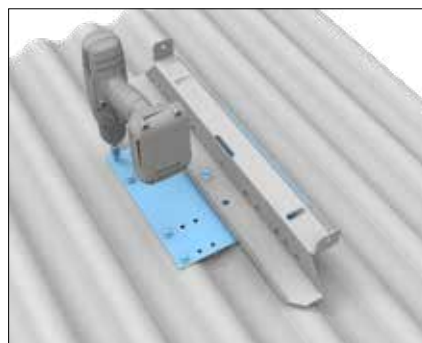
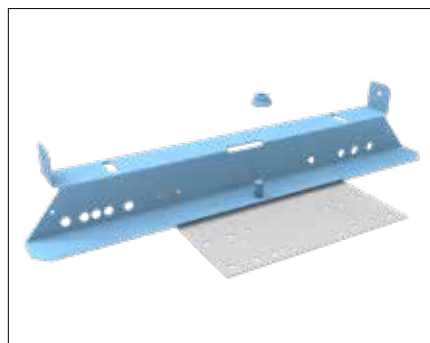

If TSK is used (roof ladder or walkway for pitch roofs), mount it on TSKIF first, as illustrated, without tightening the nut. Mount with screw and nut from bolt set 2.

Rotate TSK and position TSKIF on a profile top on the plate at least 200 mm from the edge of the plate. Fasten TSKIF with 8 screws, from bolt set 2.

Finally tighten the nut for fastening TSK on TSKIF.

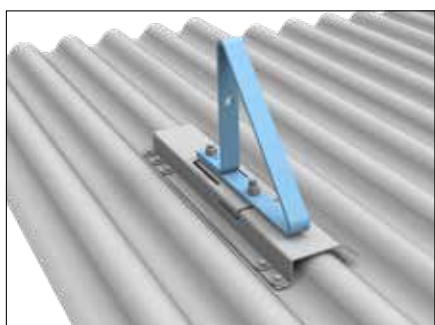

For installation with HSN (snow fence SNO) assemble HSN on IFSIN 26. Mount with 2 screws and nuts from bolt set 29, nuts positioned on the upper side. Place IFSIN 26 on the roof, fixate with 10 screws from bolt set 29.

# SRP25 Standing seam profile

## Installation requirements

SRP25 underlay.

Tighten the bolts to 40 Nm

## Fastening of bracket IFSRP on SRP25

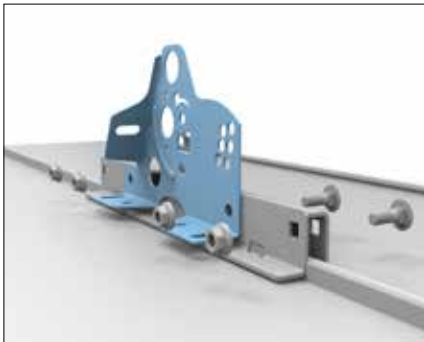

For installation with UNIK (snow guard, walkway, etc.) assemble UNIK at the same time as IFSRP. Loosen the premounted nuts on IFSRP and fasten UNIK. Ensure that the IFSRP's heels rest on the steel panel.

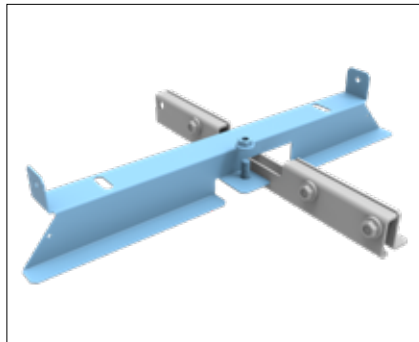

If TSKFF is used (roof ladder or walkway for pitch roofs), mount it on IFSRP first, as illustrated. Mount TSKFF on IFSRP with one screw and nut from bolt set 36, nut on the upper side. Mount together before IFSRP is fastened on the roof.

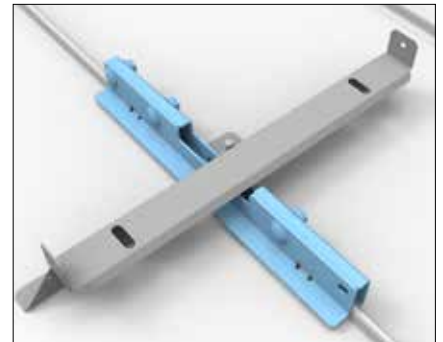

Mount IFSRP around the steel panel seam by loosen the premounted nuts and place IFSRP over the seam.



If the HSN is used (snow guard), fit it on the IFSRP first, as illustrated. Mount HSN against IFSRP with one screw and nut from bolt set 4, nut on the upper side.

# SRP25N Standing seam profile

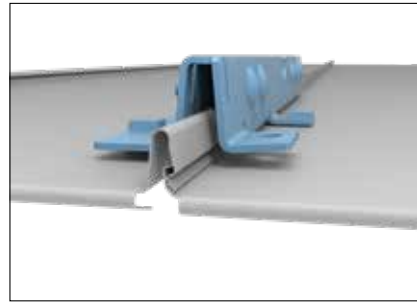

Close up on the placement of IFSRPN around the steel panel seam.

## Installation requirements

SRP25N underlay.

Tighten the bolts to 40 Nm

## Fastening of bracket IFSRPN on SRP25N

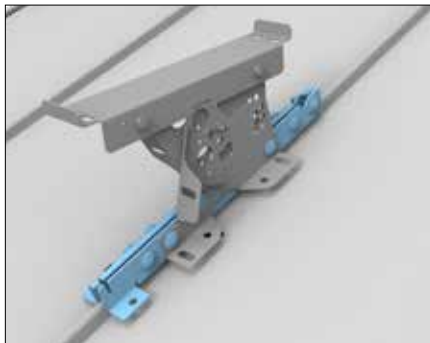

For installation with UNIK (snow guard, walkway, etc.) assemble UNIK at the same time as IFSRPN. Loosen the pre-mounted nuts from IFSRPN and fasten UNIK. Ensure that the IFSRPN's heels rest on the steel panel.

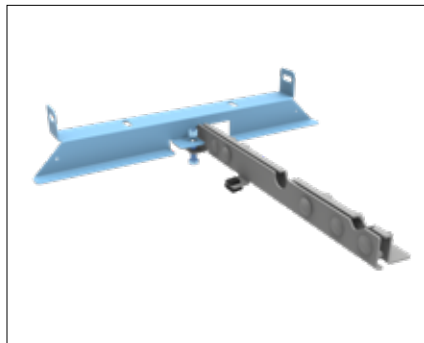

If TSKFF is used (roof ladder or walkway for pitch roofs), mount it on IFSRPN first, as illustrated with screw and nut from bolt set 36. Nut on upper side, screw from underneath.

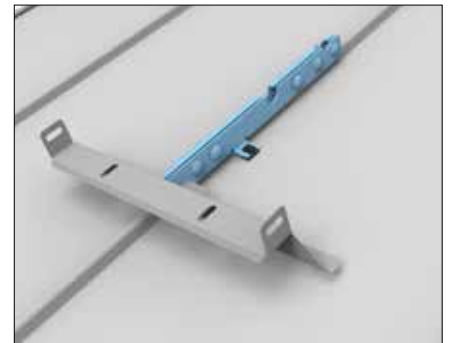

Mount IFSRPN around the steel panel seam by loosen the pre-mounted nuts and place IFSRPN over the seam.

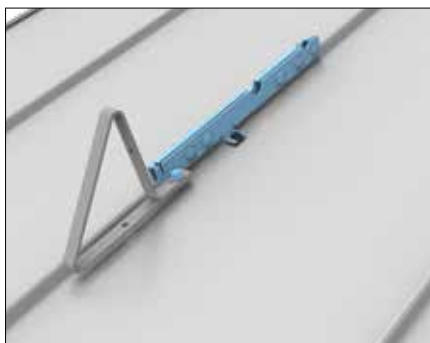

If the HSN is used (snow guard), fit it on the IFSRPN first, as illustrated. Mount with one screw and nut from bolt set 4, nut on the upper side.



If SNO is to be used (slotted snow-system) mount it together with consol IFSRPN, as illustrated.

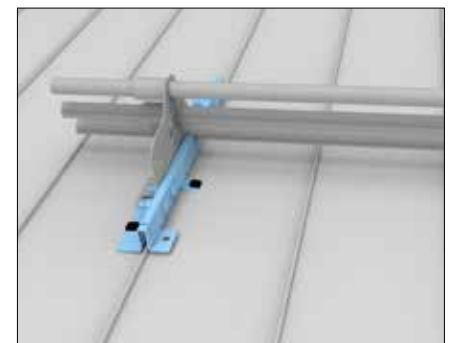

If SNO is to be used (slotted snow-system) mount it together with consol IFSRPN, as illustrated.

# Tile roofing on batten underlay

## Installation requirements

Wood: min. 19 mm

Plywood: min. 15 mm

## Fixing of KOUND on tongue and groove or plywood underlay

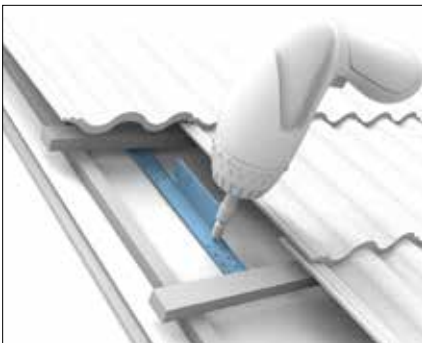

Install KOUND between battens in the desired place. Fix on the underlay with the eight accompanying screws from bolt set 20.

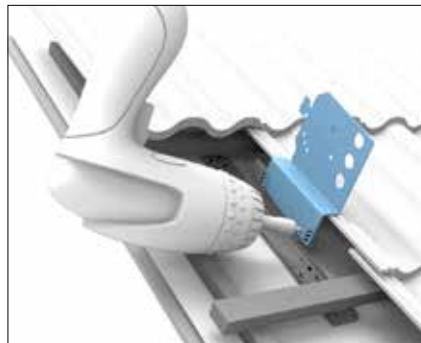

Lay KOTEG/L on the upper bracket and let it rest on the tiles. Fix in place with the two drill bit screws from bolt set 20.

Step 2 can take place on the ground to facilitate installation. Then you have to use the first bracket to determine which hole pattern is optimal for the pitch.

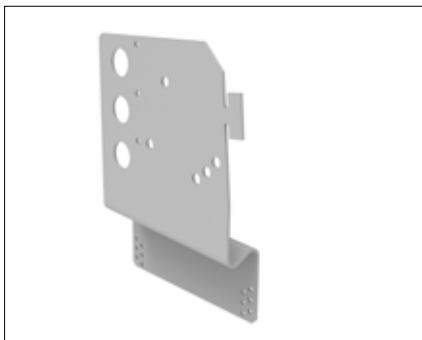

KOTEG can be used for installation of all protective equipment except for ladders: e.g. roof walkway, guard, ROR snow guard.



KOTEG/L can be used for installation of all protective equipment except for roof walkways or ladders: e.g. guards, ROR snow guard.

# Tile roofing on light underlay

## Installation requirements

Min. 45x70 batten.

### Fastening of KLF on battens for light underlay



Fit KLF supporting bracket on the batten and fasten in place with the four accompanying screws where they fit against the batten - two in the upper and two in the lower batten.

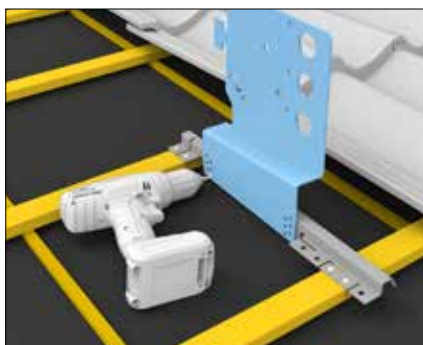

Lay KOTEG/L on the upper bracket and let it rest on the tiles. Fix in place with the two drill bit screws - one on each side of the bracket.

Step 2 can take place on the ground to facilitate installation. Then you have to use the first bracket to determine which hole pattern is optimal for the pitch.

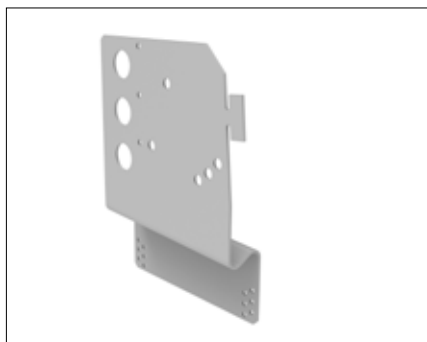

KOTEG can be used for installation of all protective equipment except for ladders: e.g. roof walkway, guard, ROR snow guard.



KOTEG/L can be used for installation of all protective equipment except for roof walkways or ladders: e.g. guards, ROR snow guard.

# Trapezoidal profile 115

## Installation requirements

Steel sheet: min. d = 0.5 mm

The installation takes place entirely from the roof's exterior.

### Fastening of IF306-245 for LHP115



For installation with UNIK (snow guard, walkway, etc.) assemble UNIK on IF115.



Position IF115 on a profile top on the plate at least 200 mm from the edge of the plate. If steel thickness is 0.9 mm or less use 8 point screws from bolt set 31 and for steel thickness 1.0 or more use 8 drill bit screws from bolt set 31 to fix IF115.



If the HSN is used (snow guard), fit it on the IF115 first, as illustrated. Use one screw and nut from bolt set 4 to fix HSN and IF115 together.

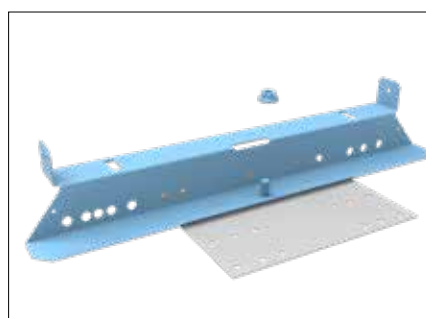

If TSK is used (roof ladder or walkway), mount it loosely on TSKIF first, as illustrated, with one screw and nut from bolt set 36.

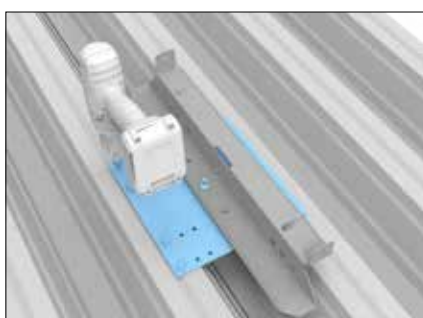

Rotate TSK and position TSKIF on a profile top on the plate at least 200 mm from the edge of the plate. Fasten TSKIF with eight screws from bolt set 2.

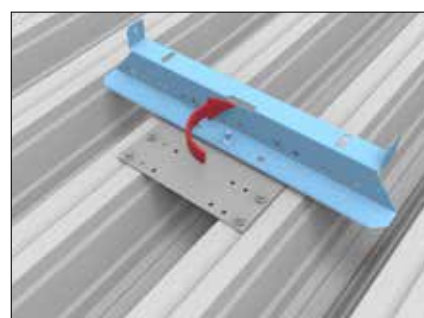

Finally tighten the nut to fasten TSK on TSKIF.

# Trapezoidal profiled steel sheet

## Installation requirements

Steel sheet: min.  $d = 0.5$  mm

The installation takes place entirely from the roof's exterior.

## Fastening of IF20, IF35, IF45, STKIF

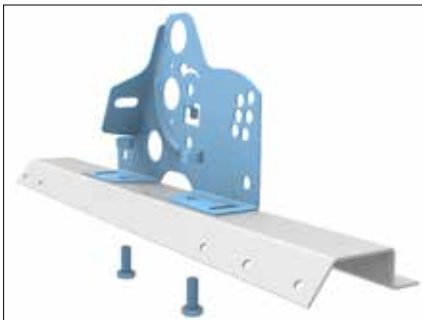

For installation with UNIK (snow guard, walkway, etc.) assemble UNIK on IF20, IF35, IF45.



Position IF20, IF35, IF45 on a profile top on the plate at least 200 mm from the edge of the plate. Fasten IF20, IF35, IF45 with the 8 accompanying screws.



If the HSN fastening eye is used (snow guard), mount it on IF20, IF35 or IF45 first, as illustrated.

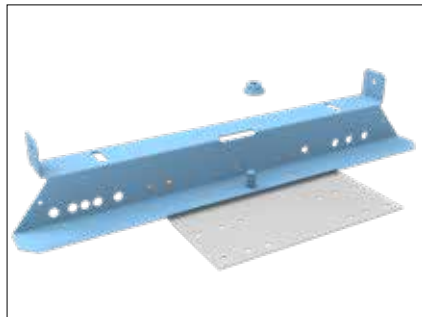

If TSK is used (roof ladder or walkway), mount it on TSKIF first, as illustrated.

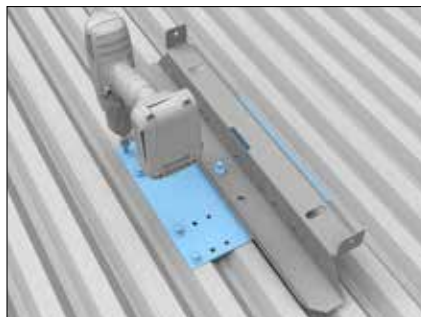

Rotate TSK and position TSKIF on a profile top on the plate at least 200 mm from the edge of the plate. Fasten TSKIF with eight drill bit screws from bolt set 23.

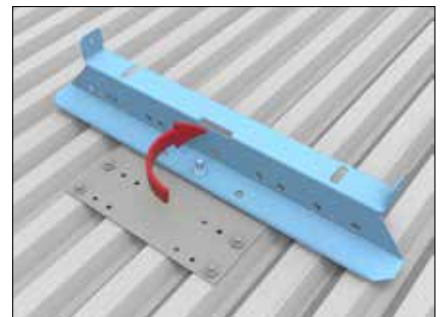

Finally tighten the nut to fasten TSK on TSKIF.

# Pivot bolt and retaining bracket

## Installation requirements

Can be used for single-fold seam strip roofing and flat battened roof.

Tongue-in-groove board min. 22 mm  
Plywood min. 18 mm

## Fastening of VIPPBULT



Mark where the holes will be drilled for console UNIK or TSK. .

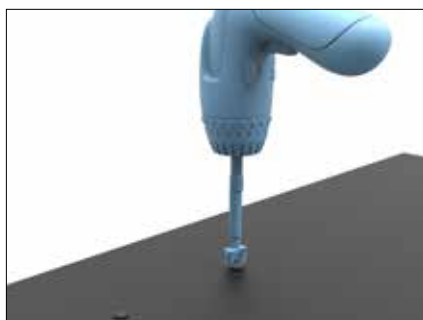

Drill through the roof with a Ø 24 mm bit.

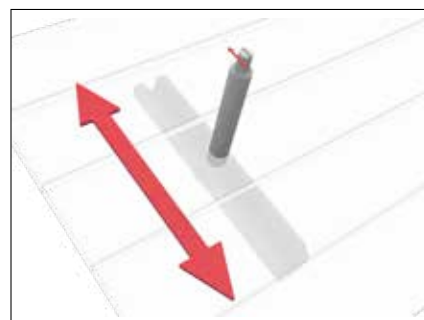

The slot in the screws must align with the console.



Fit the rubber cone on the assembly tool VIV and then screw VIV on VIPPBULT. Guide VIPPBULT through the hold and then pull it up when the opposing hole faces the side.

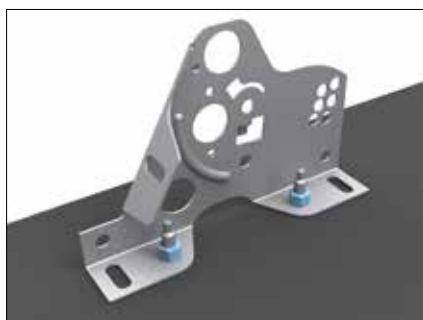

Fasten the bracket on the screws. Tighten the nuts to 35-50 Nm. NOTE: Do not shorten the screws. The groove in the screws must be parallel with the bracket so that the VIPPBULT is positioned immediately beneath the boards.

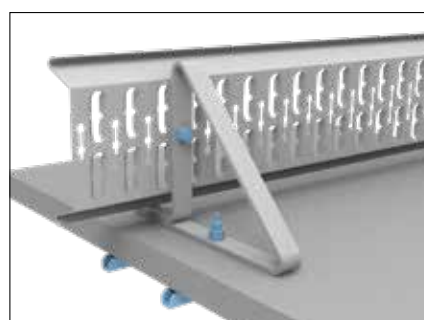

To use console HSN fasten with 2 VIPP-bolts. Fasten the console on the screws. Tighten the nuts to 35-50 Nm.

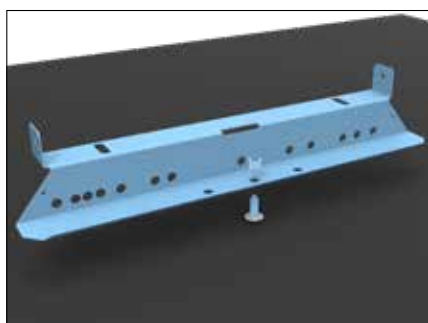

Fasten TSK to the VIPP-bolt. Maximum distance between consoles 1,5 m. At least three consoles per ladder.

# Facade ladder

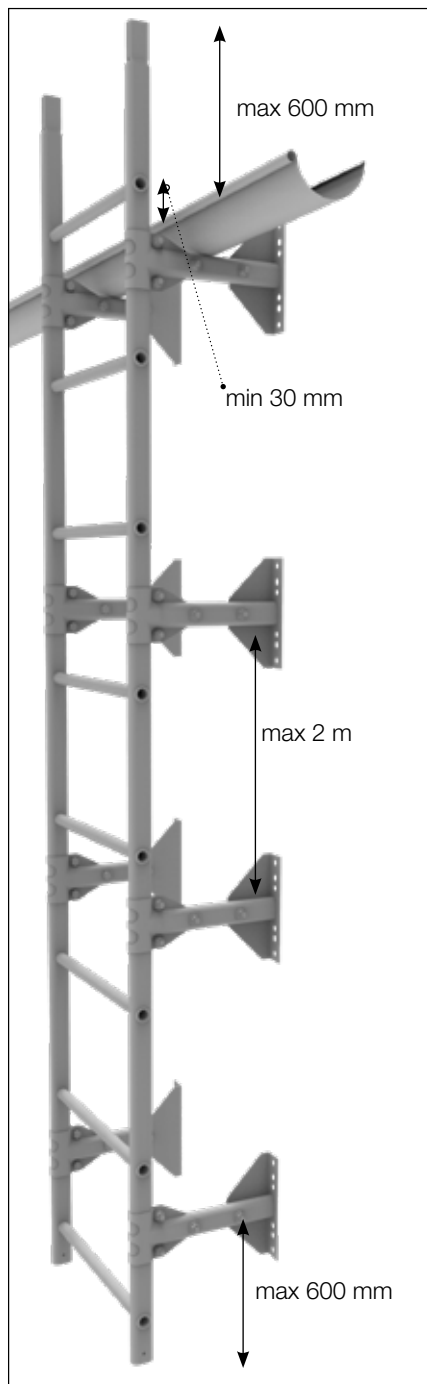

- Mount brackets with a maximum distance of 2 m between battens.
- The top rung on the ladder must be at least 30 mm above the gutter.
- The top and bottom bracket should be seated a maximum of 600 mm from the end of the ladder.
- The screws against the façade must withstand a minimum pull-out value of 24 kN per ladder.
- Safetybasket is not approved for fastening you personal protective equipment.

## Mounting

Use fastening elements that are suitable for the wall's construction. Vertical ladders should be mounted with fastening elements equivalent to a total pull-out force of 24 kN in order to fulfil 2015 industry standards. When fastening on a wall with profiled steel (min. thickness 0.5 mm), the wall ladder fastener VFSTE or fastening profile IF must be used. When mounting facade ladder on wooden/brick wall VSK wall console is used, thereafter you need to choose fastening for your specific wall-type that holds min. 25kN for the whole ladder length. Take help of the sizing values of screw manufacturer to calculate how many screws you need for your ladder. min 1 screw per VSK, all VSK must be used.

## Brackets

C-C between fastening hole and wall bracket VSK is 435 mm on all dimensions.



In order to ensure that children cannot reach the ladder, we recommend that it ends 2 m above the ground. A separate ladder can be fastened with UBVAS suspension fitting. Alternatively, a climbing barrier is mounted at the bottom of the ladder near the ground if a full-length ladder is desired.

Length of ladder	No. of rungs
1,500	5
1,800	6
2,400	8

# Facade ladder

## Assembly of TVS on VSK

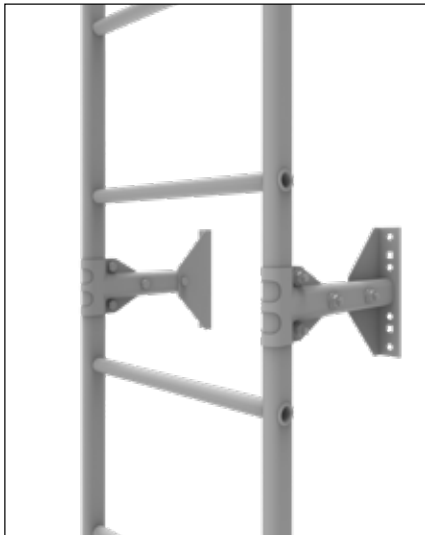

### Dimension 150 – 350

Is installed with bolt set BULTS 38.

2 screws and nut 45mm through and 2 screws and nut 25mm to fix the glove around the ladder.

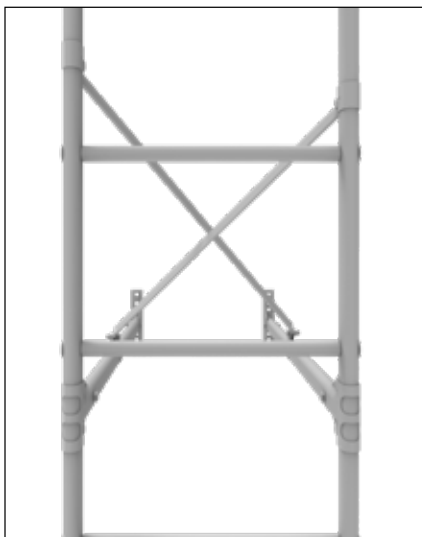

### Dimension 650 –1000

Installed with bolt set BULTS 39.

2 screws and nut 45mm through and 2 screws and nut 25mm to fix the glove around the ladder.

Diagonal restraint VSKSL and VSKSF are mounted crosswise with 4 screws and nut from bolt set 39.

## Installation requirements

It is possible to adjust the length of VSK based on your needs, cut using a hacksaw and then repaint the surface.

If the holes are cut away, new ones need to be made on 11 Ø in the middle of the pipe and 80mm from the edge.

# Facade ladder

## Joining the ladder

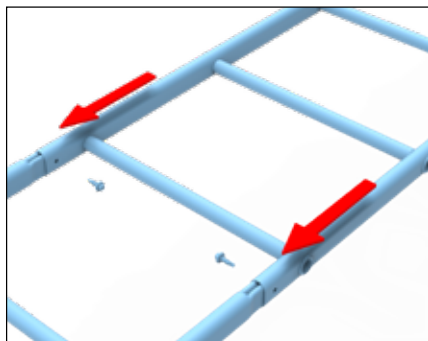

The ladder is joined by guiding the crimped end into the upper ladder. Fasten them together with a drill bit screw.

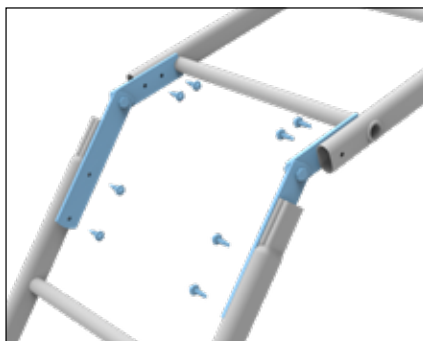

If the ladder cannot be joined at an angle, TSSV, which is screwed into the rung sides with eight drill bit screw, is used.

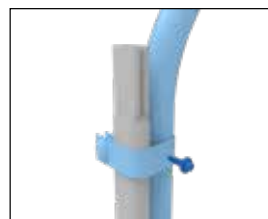

## UBVAS



If a climbing barrier is not installed, the ladder must end 2 m above the ground so that children cannot reach it. The suspension fitting UBVAS can be used in order to reach the ladder from below. UBVAS is mounted with 4 accompanying drill bit screws.

## VSHL

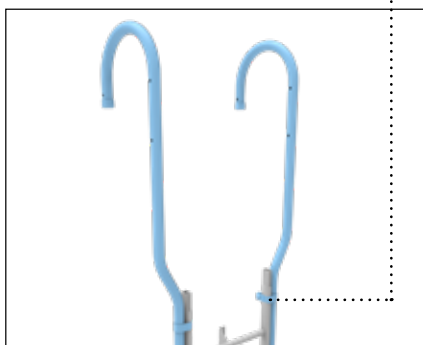

Mount the VSHL handrail if necessary.

When mounting handrails, fasten with 2 extra screw for extra stability, as illustrated.

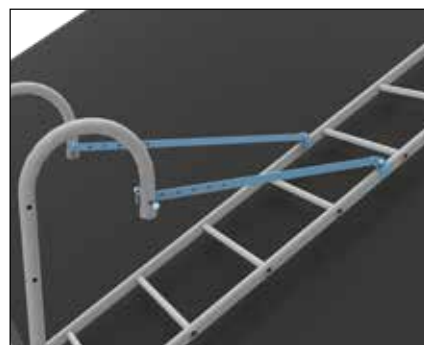

Also mount HALKSTVS coupling between handrail and ladder. Fasten coupling HALKSTVS on handrail with screw and nut. Fasten glove VSKSF on ladder with two screws and nut.

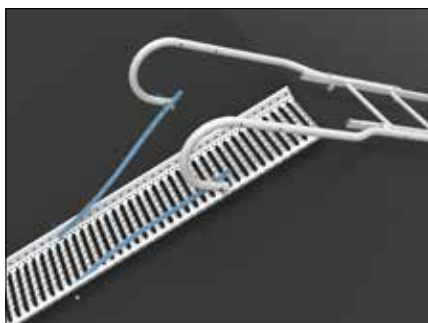

Also mount coupling HALKSBR between handrail and ladder. Fasten coupling HALKSBR against walkway with 2 screws and nut and against handrail with 2 screws and nut.

## KLHIN climbing obstacle



Climbing obstacle to be hooked on to the rung, locked with a padlock.

# Facade ladder

## Protective cage

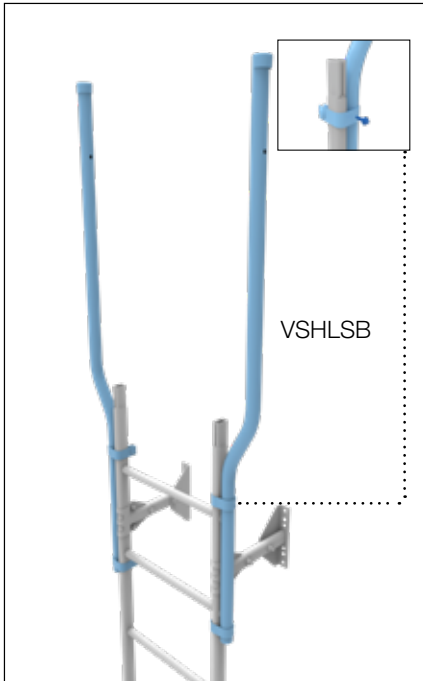

Mount the VSHLSB handrail on the ladder with the accompanying fittings. Fasten with 4 screws and nut from bolt set 24. Fix against ladder with 2 drill bit screws for extra stability.

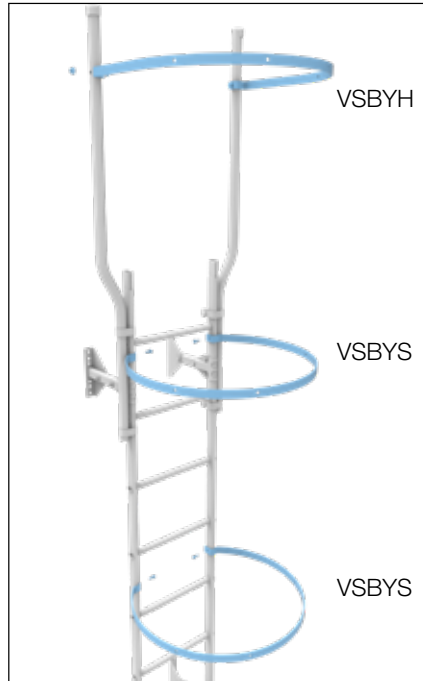

Mount the VSBYH bow on VSHLSB. Fasten VSBYH with 2 screws 60mm and 2 nuts from bolt set 41. Then mount VSBYS on the ladder with 1000 mm c-c. Fasten VSBYS with 2 drill bit screws from bolt set 40. The protective cage may end 2.5 metres above the ground.

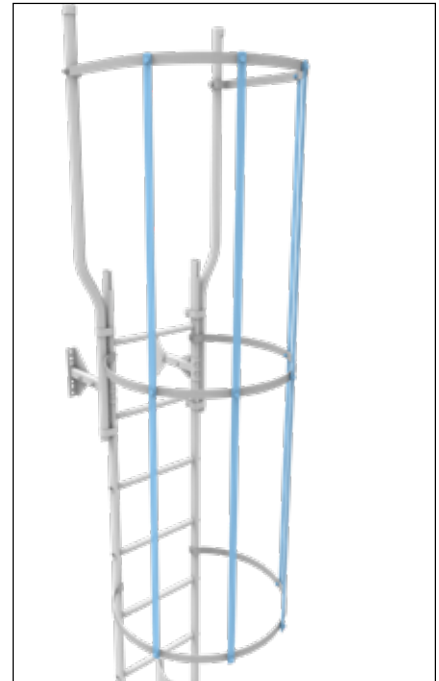

Mount stiffener for protective cage VSST. The screw head should be seated on the inside of the cage. VSST is to be mounted on VSBYS with 4 screws and nut from bolt set 40. VSST is to be mounted on VSBYH with 5 screws and nut from bolt set 41.

# Slide protection for ladders

## Installation on GLS

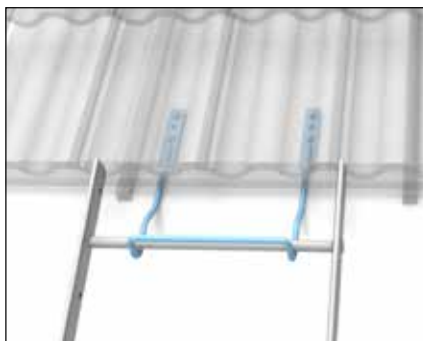
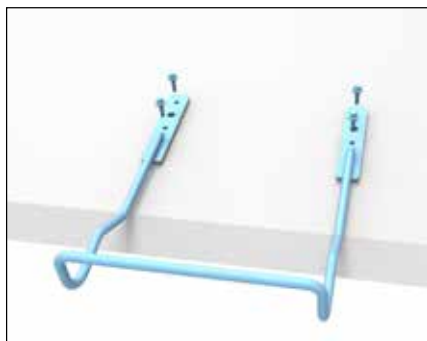

GLS slide protection is positioned at the base of the roof under the outer roof. GLS is fastened with suitable fasteners depending on the underlay. Fasten the slide protection with screws suited for the underlay and with pull-out value of 2.6 kN per slide protection. NOTE: screws are not included in the delivery.

## Installation of TSGLS

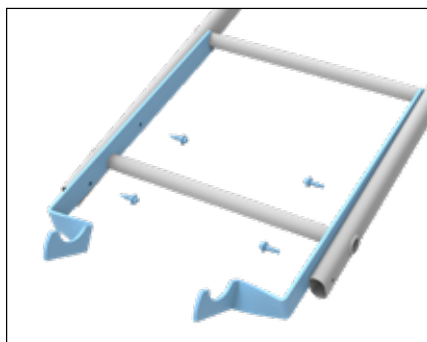

Fasten TSGLS slide protection on either side of the roof ladder and fasten with the accompanying 4 drill bit screws.

## Installation of GLSRP for SRP25 roof

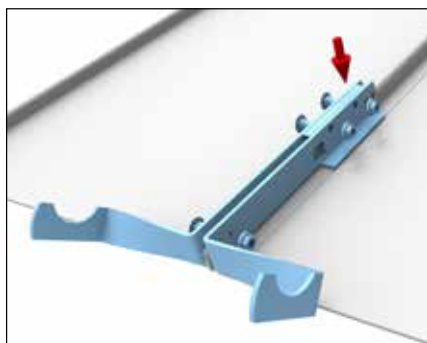

Loosen the nuts and position the slide protection over the seam. Ensure that the lower part comes down far enough for the ground ladder's connection. Tighten the three nuts with a 16 mm socket wrench. Ensure that they are tightened correctly (approx. 45-55 Nm).

# Slide protection for ladders

## Installation of FFGLS (for folded seam roof)

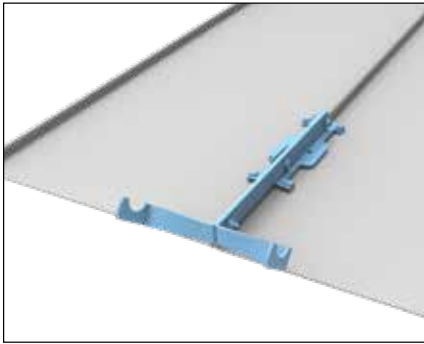

Loosen the nuts and position the slide protection over the seam. Ensure that the lower part comes down far enough for the ground ladder's connection. Tighten the three nuts with a 16 mm socket wrench. Ensure that they are tightened correctly (approx. 45-55 Nm).

## Installation requirements

When mounting on copper-roofs insulation profile FFIP must be used.

# Sliding protection for ladder

## Installation of GLSPAPP

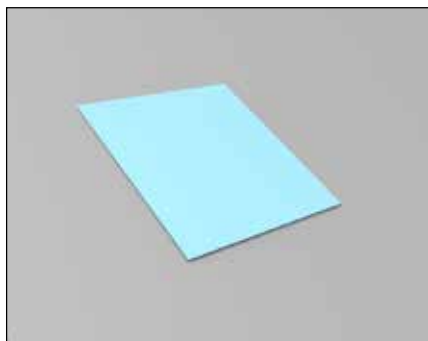

Cut a piece of min 500\*400 of the felt that will be on the roof. Put it where the plate will be mounted with the underside up.

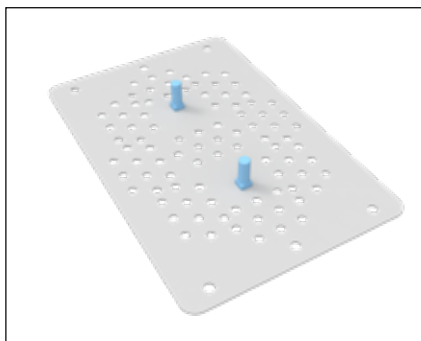

Mount 2 bolts from bolt set 26 from the underside on TATPLATGLS.

## Installation requirements

Sliding protection for roofs on wooden underlaying roof, GLSPAPP.

Approved regardless of sealing layer type.

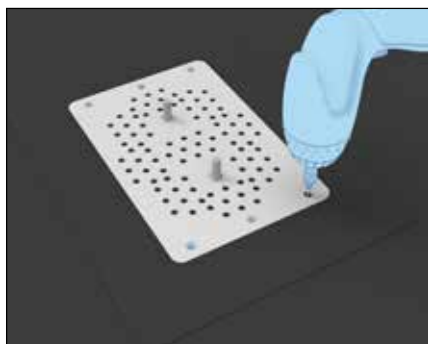

Put the plate TATPLATGLS on the felt and fasten with 6 wood screws from bolt set 26.

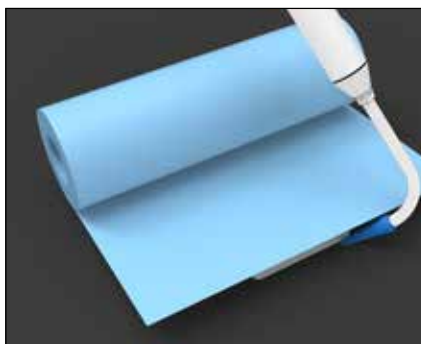

Put out the paper and make holes for the bolts. Heat the roofing felt so that it fuses with the underlying layer patch through the perforation.



Mount the angle VIPAPP to the plate. use the accompanied rubber washer GRB from bolt set 26 below the angle and nut from bolt set 26. .



Mount VINGEH and VINGEV with the 3 accompanied screws and nuts.

# Installation on ladder and standing plate on chimney

## Installation requirements

The chimney-ladder is not approved as fastening for your personal protective system.

Chimney width	SKBA chimney strap	HGS threaded bar	SKBASF
500–760	460	350	must be used
760–1,000	460	650	must be used
1,000–1,260	960	350	
1,260–1,500	960	650	
1,500–1,760	1,460	350	
1,760–2,000	1,460	650	

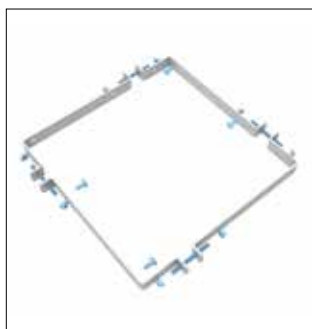

Install the SKBA chimney straps with stainless threaded bar HGS Ø 10 mm. Prepare with 2 accompanied bolts in the holes on which the brackets will be fastened. Mount with 8 accompanied nuts per strap.

SKBASF must be used for SKBA 460. To be fixed with 2 accompanied screws and nuts.

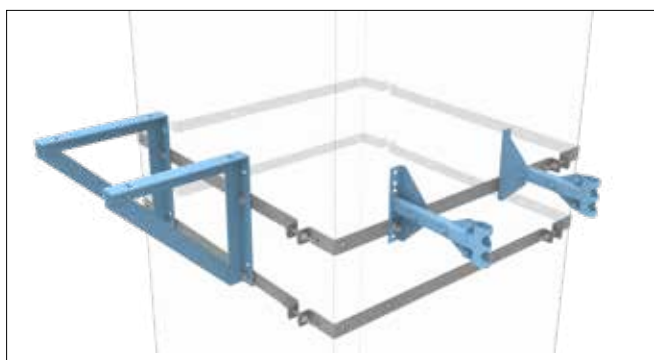

Mount the two fittings with SKKO bracket for roof walkway BR, use screw and nut from bolt set 5 and wall bracket VSK for ladder TVS with 2 accompanied screws and nuts.

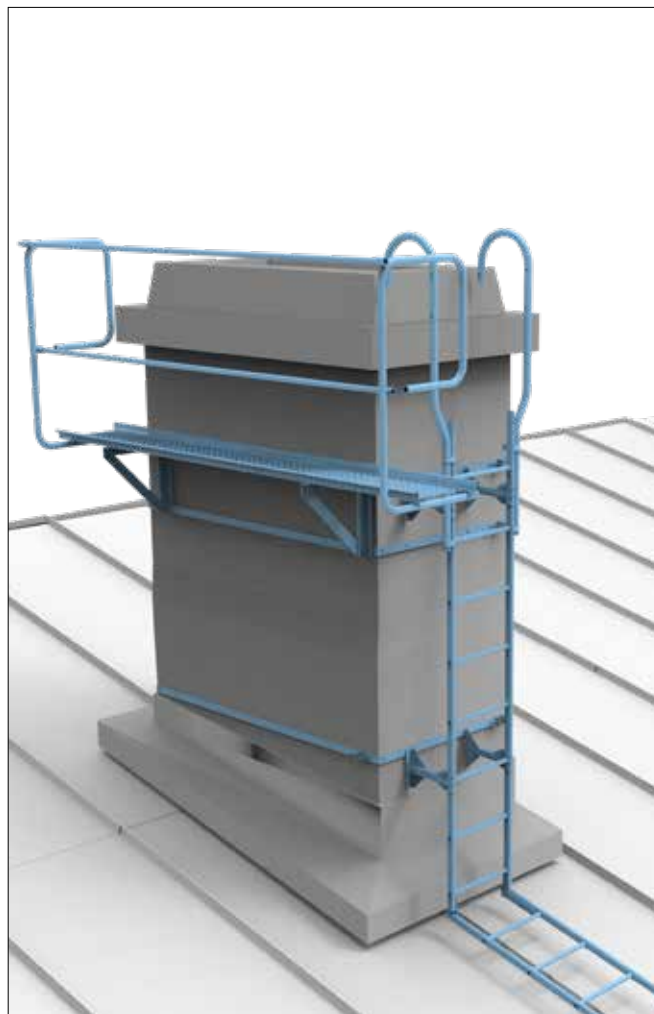

Mount the ladder on the bracket. Continue by mounting the other straps for ladders with max. 2 m c-c. Mount the roof walkway with a guard STANDN. Fasten the walkway with 2 screws and nuts per SKKO from bolt set 5. Fasten VSSP with 4 included drill bit screws.

# Ridge rail - ROR

## Installation of ROR as ridge rail on KOBET/L, KOTEG/L and UNIK

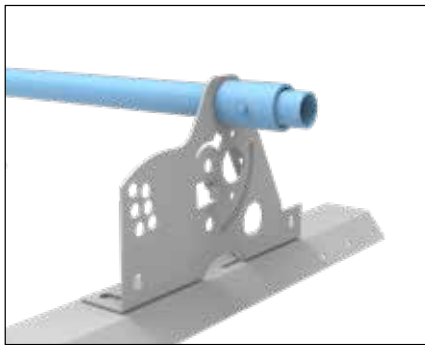
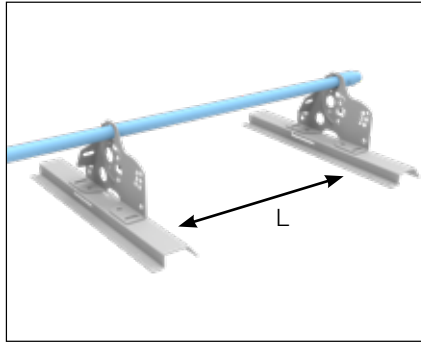
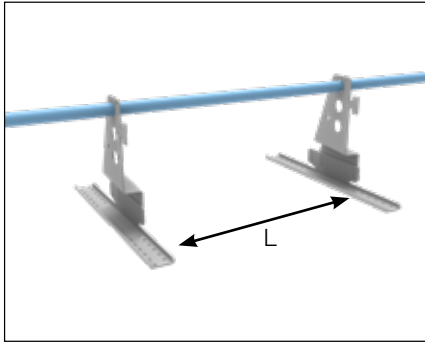

Position the ROR tube in the top bracket hole. Mount the AND end sleeve as close as possible to UNIK. Max. overhang 300 mm. Mount AND with 1 accompanied drill bit screw.

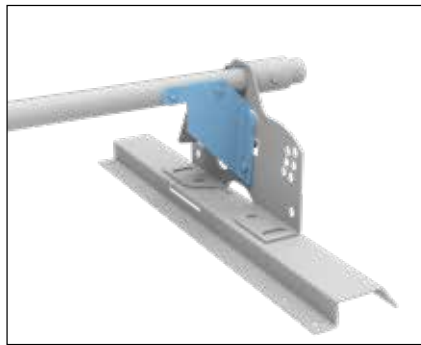

Mount the supporting bracket (SVI) on the tube. Only one supporting bracket is needed per rail length. Mount SVI med 2 drill bit screws towards ROR and one screw and nut towards console UNIK.

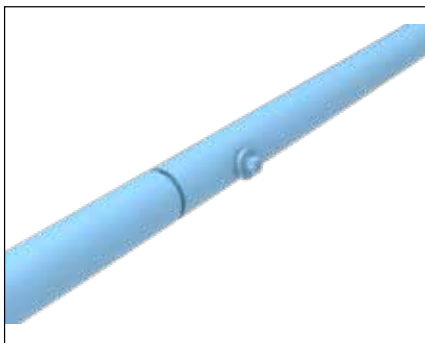

If necessary, ROR can be joined by threading the crimped end over the non-crimped one and fastened with the supplied drill bit screw.

### Installation requirements

- Bottom brackets are fastened on the underlay according to instructions
- The distance L is max. 1200 mm, but varies for different snow zones. Visit [www.roofsafetysystems.se](http://www.roofsafetysystems.se) to determine the correct distance for brackets. Always assemble with minimum three brackets.
- It is possible to adjust the length of ROR with the help of a hacksaw, then repaint

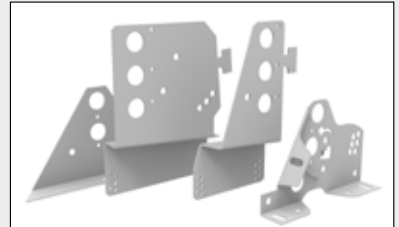

The brackets that can be used for snow protection with ROR are SAWK, KOBET/L, KOTEG/L and UNIK. The brackets must be fastened in the roof according to instructions.

# Snow guard - with ROR

## Installation of ROR as snow guard on KOBET/L, KOTEG/L and UNIK

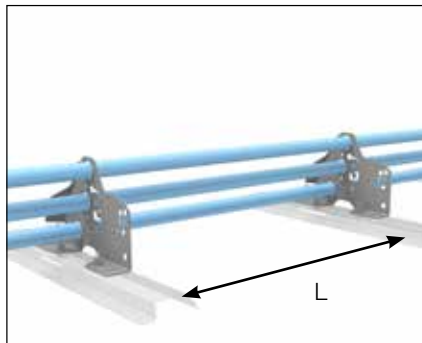
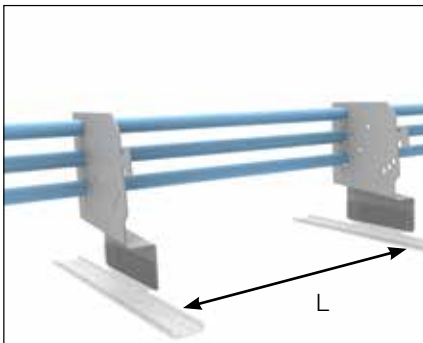

### Installation requirements

- Bottom brackets are fastened on the underlay according to instructions
- The distance L is max. 1200 mm, but varies for different snow zones. Visit [www.roofsafetysystems.se](http://www.roofsafetysystems.se) to determine the correct distance for brackets. Always assemble with minimum three brackets.
- It is possible to adjust the length of ROR with the help of a hacksaw, then repaint

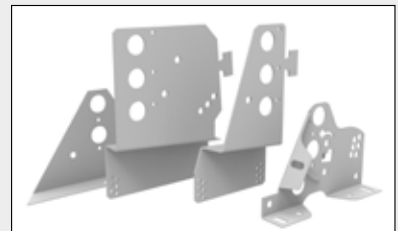

The brackets that can be used for snow protection with ROR are SAWK, KOBET/L, KOTEG/L and UNIK. The brackets must be fastened in the roof according to instructions.

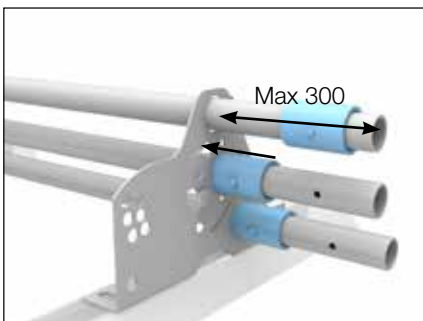

Position the ROR tube in the bracket holes. Mount the AND end sleeve on all tubes as close as possible to UNIK. Max. overhang 300 mm. Mount AND with 1 accompanied drill bit screw.

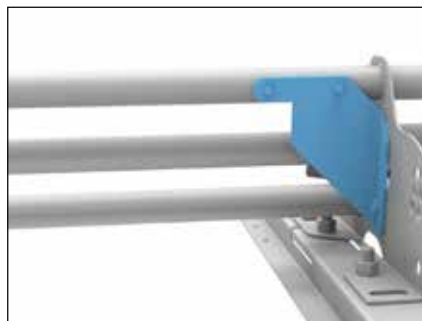

Mount the supporting bracket (SVI) on the top tube. Only one supporting bracket is needed per guard length. Mount SVI med 2 drill bit screws towards ROR and one screw and nut towards console UNIK.



Use HRN corner connection for angles. Fix it in place with the two accompanying drill bit screws per angle.

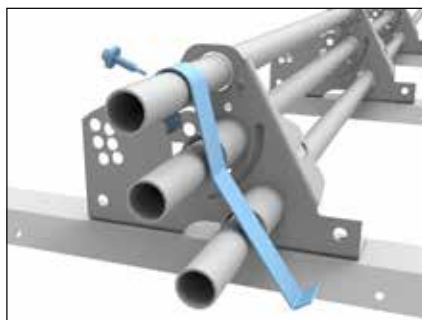

Fasten ISSTOPP on the top tube with a drill bit screw. 5 are installed per metre of snow guard. ISSTOPP can also be installed on the middle tube if necessary. Fix ISSTOPP with 1 included drill bit screw.

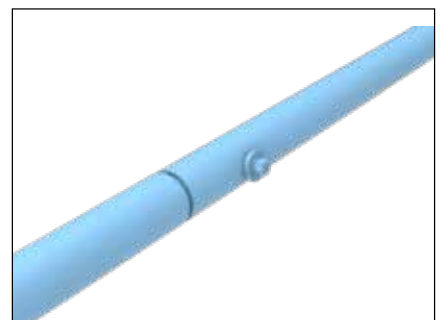

If necessary, ROR can be joined by threading the crimped end over the non-crimped one and fastened with the supplied drill bit screw.

# Snow guard - *with ROR*

## Installation of ROR as snow guard and ridge rail on SAWK (sandwich roof)



Guide the two top tubes in the SAWK bracket (if ridge rail, only one tube in the top hole). Use AND tube end in each tube end. Fasten AND as close to SAWK as possible. Fix AND with 1 accompanied drill bit screw.



Install SAWSG ice sliding guard between tops on the sandwich panel. Use the 4 accompanying drill bit screws and overlap SAWSG.

# Snow guard - with SNO

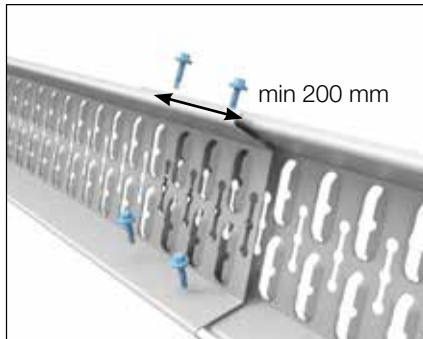
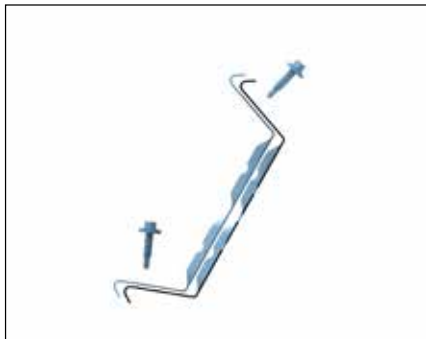

When extending, SNO is installed with min. wraparound of 200 mm. Every joint is locked with four accompanied drill bit screws as illustrated.

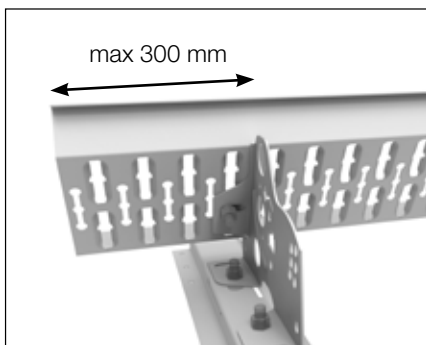

Max. overhang 300 mm.

## Installation requirements

- Bottom brackets are fastened on the underlay according to instructions
- Always assemble with minimum three brackets.
- It is possible to adjust the length of SNO after your need, cut using a hacksaw and then repaint the surface

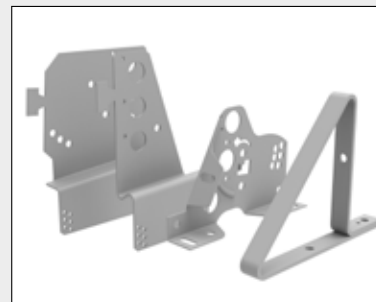

The brackets that can be used for snow protection with SNO are KOBET/L, KOTEG/L, UNIK and HSN. The brackets are fastened on supporting brackets that are chosen based on roof construction and fastened according to instructions.

## Installation of SNO as snow guard

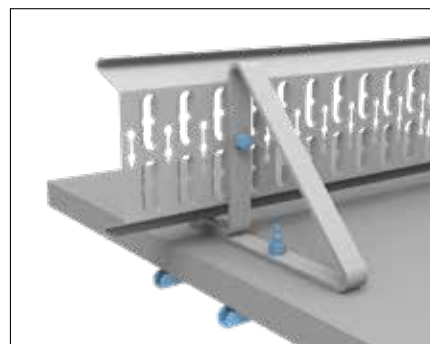
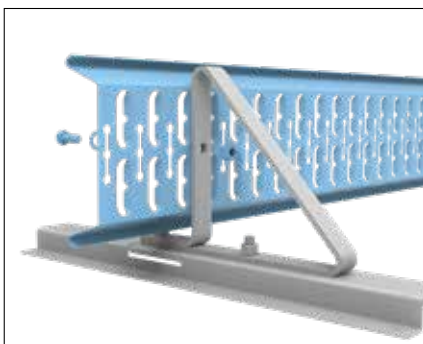
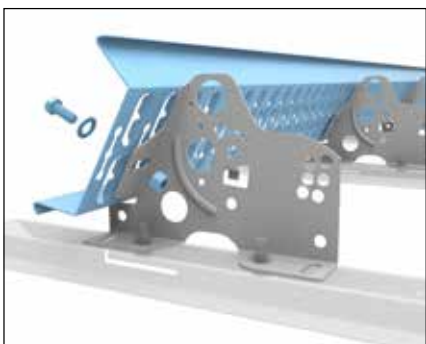

Install SNO snow guard with bolt and washer from bolt set 4 for UNIK and HSN brackets. The distance between the roof (profile top on tile and profiled sheet) and the snow guard's lower edge must not exceed 30 mm.

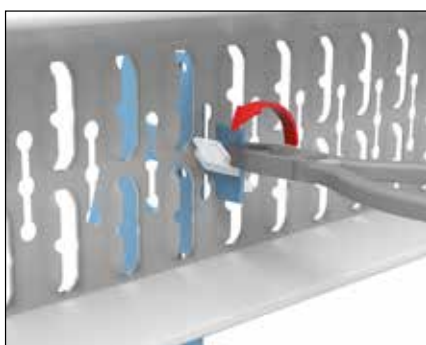

Install SNO snow guard on KOBET/L or KOTEG/L by twisting the lock washer around with pliers. The distance between the roof (profile top on tile and profiled sheet) and the snow guard's lower edge must not exceed 30 mm.

# Snow guard - with SNO

## Assembly of ISSTOPP on SNO

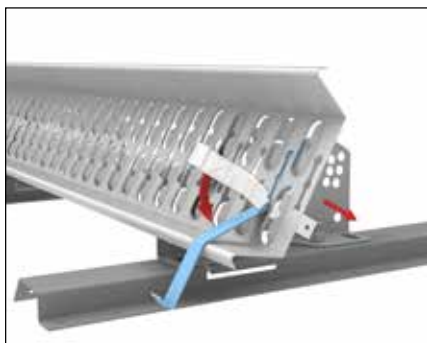

With use of UNIK bracket: Guide ISSTOPP in the bottom recess and rotate into position. 5 are installed per metre of snow guard.

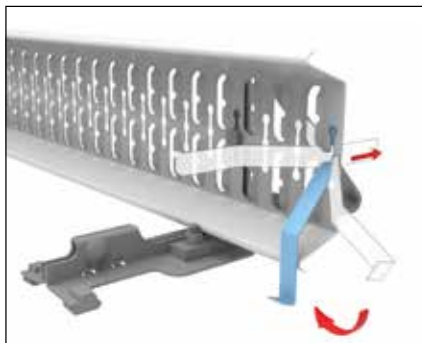

With use of HSN bracket: Guide ISSTOPP in the middle recess and rotate into position. 5 are installed per metre of snow guard.

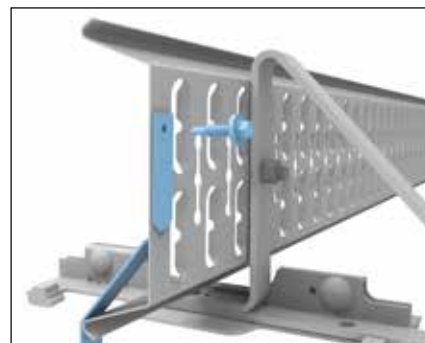

Fasten ISSTOPP with a drill bit screw.

## Assembly of IS115S on SNO

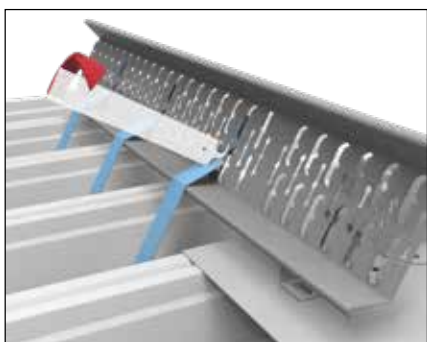

With use of UNIK bracket: Guide IS115S in the bottom recess and rotate into position. 5 are installed per metre of snow guard.

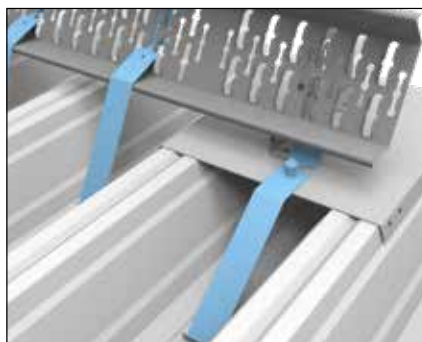

With use of consol UNIK: fasten IS115S in the IF115 plate with on accompanied drill bit screw.



With use of HSN bracket: Guide IS115S in the bottom recess and rotate into position. 5 are installed per metre of snow guard.

## Assembly of ISKRATTA on SNO



With use of consol HSN: fasten IS115S in the plate IF115 with one accompanied drill bit screw.

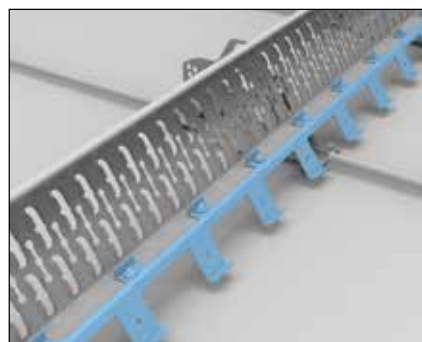

With use of consol UNIK: fasten ISKRATTA with the 6 accompanied drill bit screws.

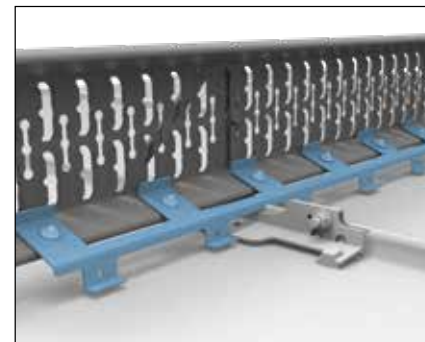

With use of consol HSN: fasten ISKRATTA with the 6 accompanied drill bit screws.

# Guard rail

## Installation requirements

- Bottom brackets are fastened on the underlay according to instructions
- A maximum pole spacing of <math><1200\text{ mm}</math> is used for long guard rails.

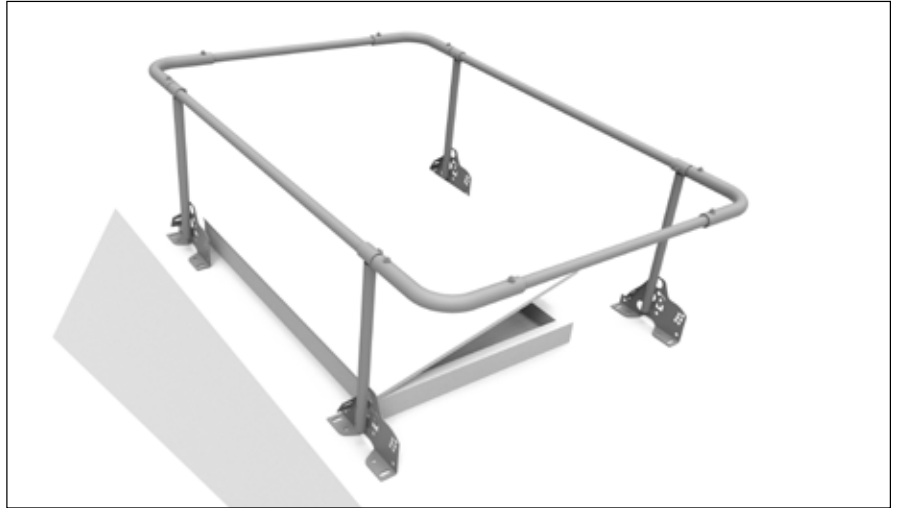

Various versions can be used with guard rail.



# Guard rail



The brackets that can be used for protective rail are KOBET/KOBETL, KOTEG/KOTEGL, UNIK and SAWK. The bracket is installed in the underlay according to the installation instructions for various fastening types.

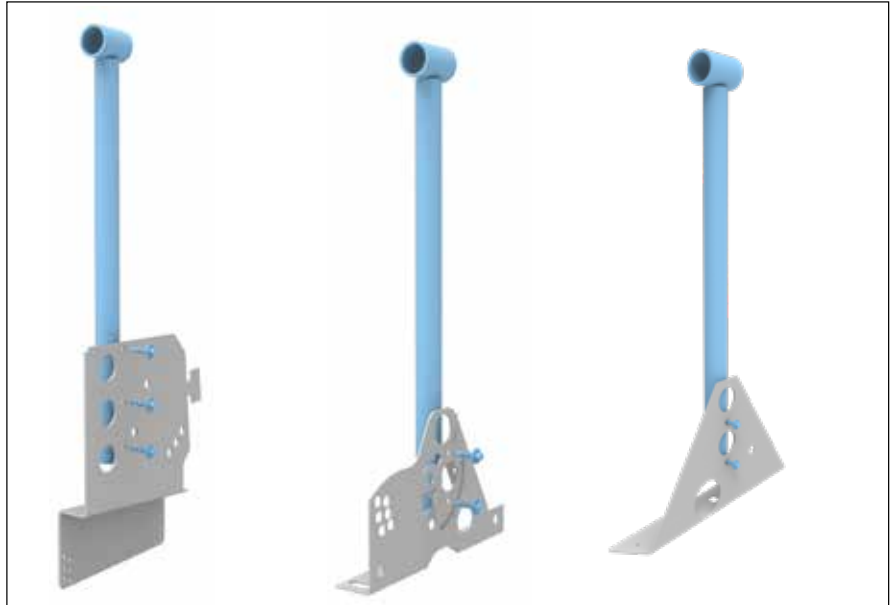

Mount the SRTT pole on the bracket with three accompanying drill bit screws for installation on KOBET/L, KOTEG/L. Two accompanied drill bit screws for UNIK and SAWK.



Fix SRTT in ROR with one accompanying drill bit screw.



Fit ROR pipes and HRN corners together. Fix it in place with 2 accompanying drill bit screws.



If stabilisation is necessary, SRTTST stabilisation stiffener is installed on the pole. Use the two accompanying drill bit screws.

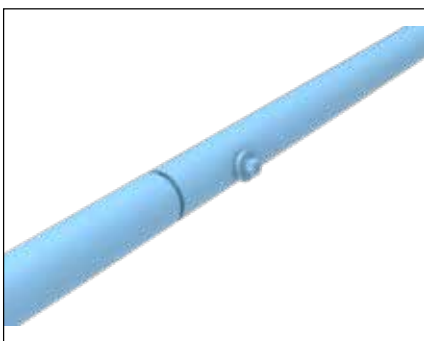

If necessary, ROR can be joined by threading the crimped end over the non-crimped one and fastened with the supplied drill bit screw.

# Roof walkway

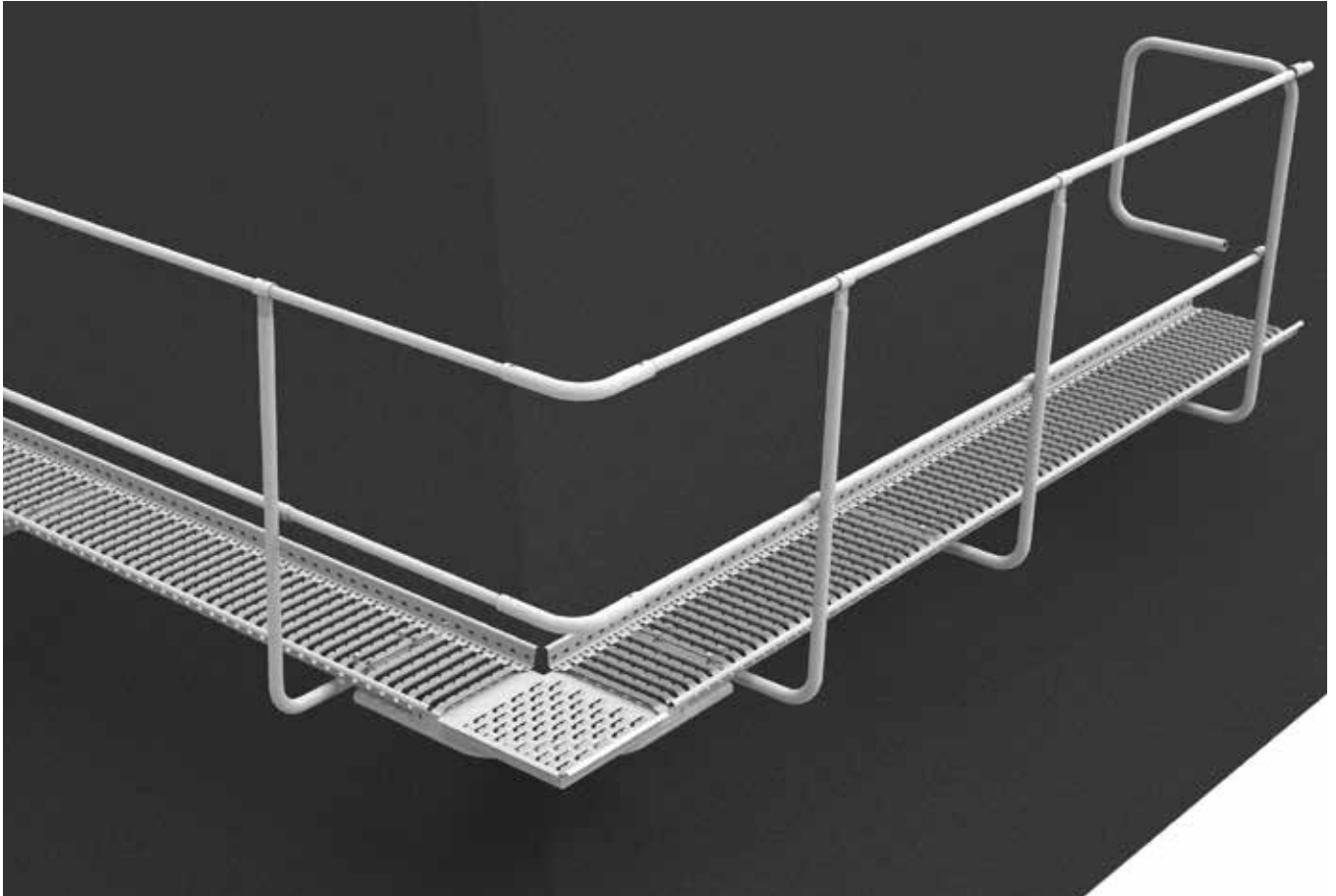

16

Lindab Profil AB

Vistorpsvägen 56, 26971 Förslöv, Sverige

Gångbrygga NR 2016

DoP nr 2016

Anmält organ: 0402

SS-EN 516:2006 class 2 type B

Walkways intended to be used as roof access for inclined roofs for buildings

Väsentliga egenskaper	Prestanda
Utförning	Class 2 enl 6.1, Typ B enl 6.2
Statisk belastning enl 7.1	Uppfyller
Dynamisk belastning enl 7.2	Uppfyller
Reaktion vid brand enl 7.3	Klass A1
Beständighet mot korrosion enl. 5	Uppfyller

## Installation requirements

It is possible to adjust the length of the walkway after your need, cut using a hacksaw and then repaint the surface.

When working attached to the bridge, hold 4 meters distance between each person.

# Roof walkway with brackets

## Assembly with console UNIK

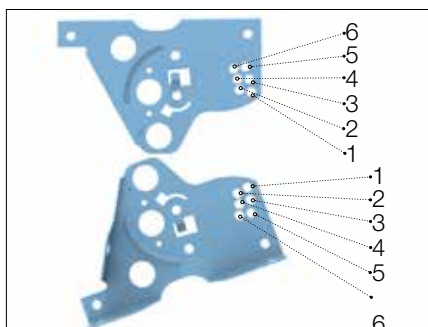

Roof slope		
5°	=	1+1
10°	=	2+2
15°	=	1+3
20°	=	4+2
25°	=	5+1/3+3
30°	=	6+2/4+4
35°	=	3+5
40°	=	4+6
45°	=	5+5
50°	=	6+6

Adjust the angle according to chart.

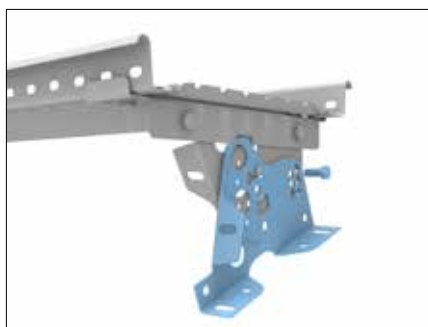

Attach UNIK in UNIKBR.

# CE

16

Lindab Profil AB

Vistorpsvägen 56, 26971 Förslöv, Sverige

Gångbrygga NR 2016

DoP nr 2016

Anmält organ: 0402

SS-EN 516:2006 class 2 type B

Walkways intended to be used as roof access for inclined roofs for buildings

Väsentliga egenskaper	Prestanda
Utformning	Class 2 enl 6.1, Typ B enl 6.2
Statisk belastning enl 7.1	Uppfyller
Dynamisk belastning enl 7.2	Uppfyller
Reaktion vid brand enl 7.3	Klass A1
Beständighet mot korrosion enl. 5	Uppfyller

# Roof walkway with brackets

## Assembly with KOBET/KOTEG

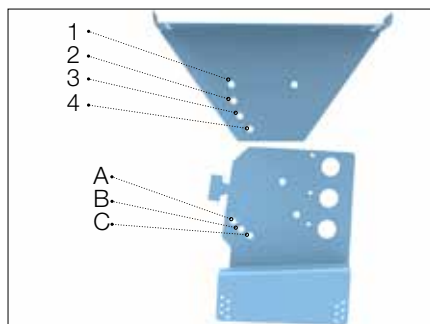

Adjust angle according to chart



Attach KOBR in KOBET/KOTEG with 2 screws and nuts from bolt set 10.

Roof slope	=	
5°	=	B+4
10°	=	A+3
15°	=	C+4
20°	=	B+3
25°	=	A+2
30°	=	C+3
35°	=	B+2
40°	=	A+1
45°	=	C+2
50°	=	B+1
60°	=	C+1

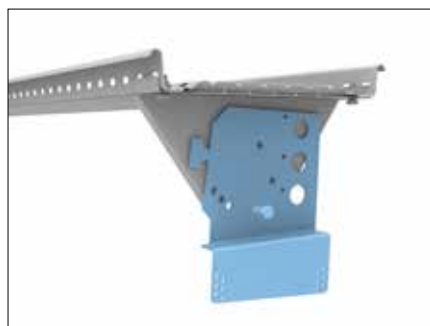

Attach walkway BR on KOBR with 2 screws and nuts from bolt set 10.

The T-bracket must be bent away when setting the maximum roof slope of 60°.

## Assembly of walkway vertically against ridge, maximum roof slope 15°

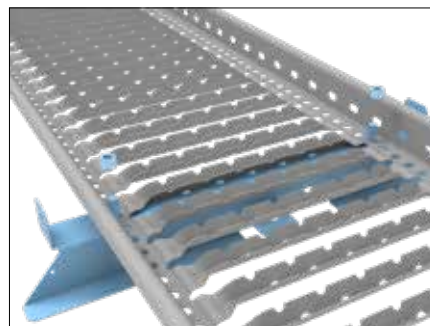

Mount BR on top of console TSKFFBR, use the 2 accompanied screws and nut.

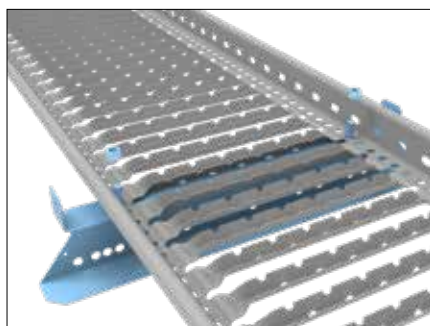

Mount BR on top of console TSKTAT, use 2 screws and nut from bolt set SKARVB.

# CE

16

Lindab Profil AB

Vistorpsvägen 56, 26971 Förslöv, Sverige

Gångbrygga NR 2016

DoP nr 2016

Anmält organ: 0402

SS-EN 518:2006 class 2 type B

Walkways intended to be used as roof access for inclined roofs for buildings

Väsentliga egenskaper	Prestanda
Uttorning	Class 2 enl 6.1, Typ B enl 6.2
Statisk belastning enl 7.1	Uppfyller
Dynamisk belastning enl 7.2	Uppfyller
Reaktion vid brand enl 7.3	Klass A1
Beständighet mot korrosion enl. 5	Uppfyller

# Roof walkway

## For installation with SAWBRK bracket

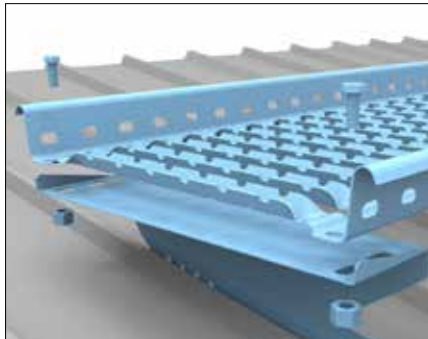

Install roof walkway BR on the SAWBRK brackets. Use two screws and nuts from bolt set 9. SAWBRK is available for two different pitches.

## BRV and BRVROR walkway bracket corner

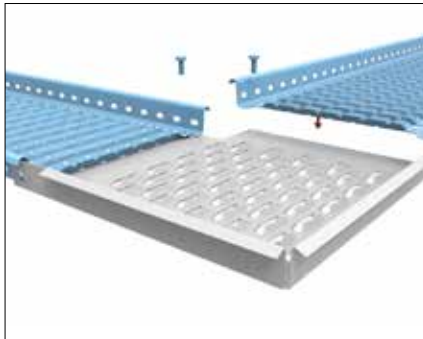

Install the walkway, BR according to the instructions. Ensure that the corners on the walkways meet. The current walkway bracket is installed with a minimum distance of 300 mm and maximum 900 mm to the end of the walkway. Fasten the walkway brackets, BRV where the walkways meet with 2 screws and nuts from bolt set BRV.

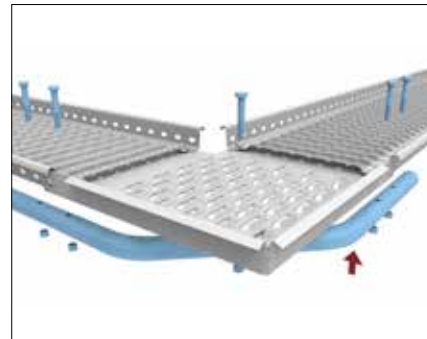

Fasten the reinforcement tube, BRVROR on the opposite side with 5 screws and nuts from bolt set BRV.

## BR joint

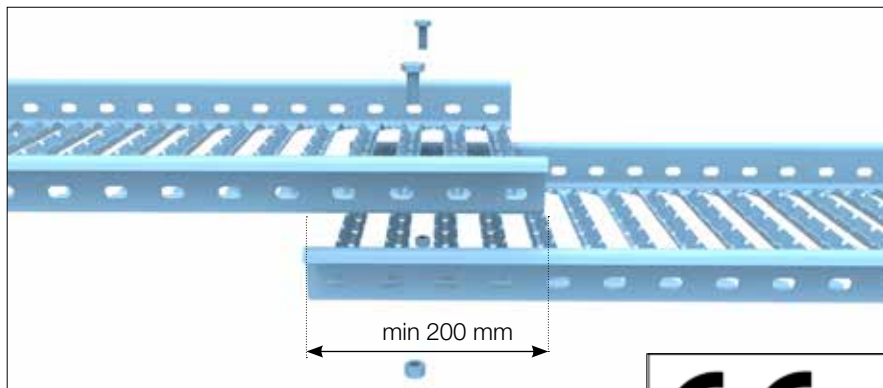

When extending, BR is installed with min. wraparound of 200mm. The joint is locked in place with two screws and nuts from bolt set SKARVBR. When joining several bridges each bridge must always rest on at least 2 brackets.

# CE

16

Lindab Profil AB

Vistorpsvägen 56, 26971 Förslöv, Sverige

Gångbrygga NR 2016

DoP nr 2016

Anmält organ: 0402

SS-EN 516:2006 class 2 type B

Walkways intended to be used as roof access for inclined roofs for buildings

Väsentliga egenskaper

Prestanda

Utförning

Class 2 enl 6.1, Typ B enl 6.2

Statisk belastning enl 7.1

Uppfyller

Dynamisk belastning enl 7.2

Uppfyller

Reaktion vid brand enl 7.3

Klass A1

Beständighet mot korrosion enl. 5

Uppfyller

# Roof walkway

## BRSTAG

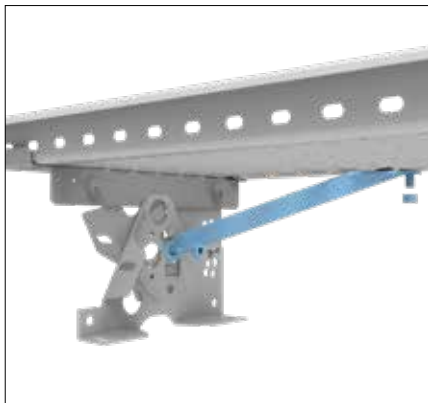

BSTAG walkway stiffener must be used. Mount with one screw and nut from bolt set 4, loosen screw and nut from the console to fix BSTAG against the console.

## Support points

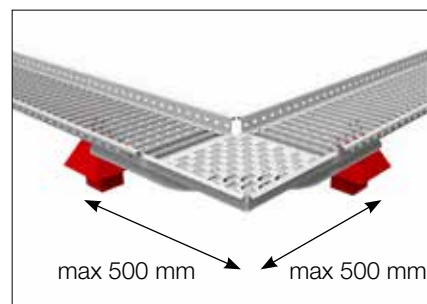
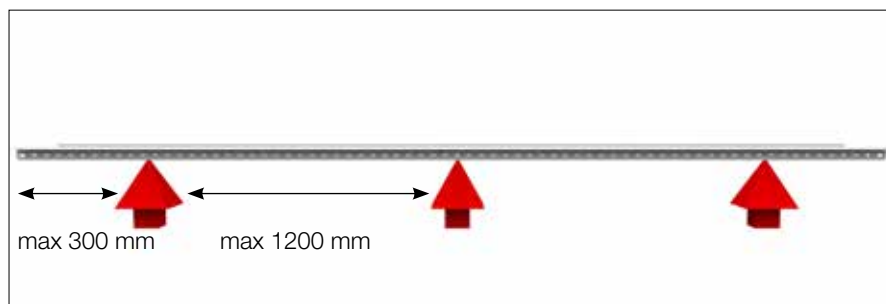

At least three brackets must be used per length. The distance between the brackets must not exceed 1200 mm. The max. overhang is 300 mm.

<b>CE</b>	
16	
Lindab Profil AB	
Vistorpsvägen 56, 26971 Förslöv, Sverige	
Gångbrygga NR 2016	
DoP nr 2016	
Anmält organ: 0402	
SS-EN 516:2006 class 2 type B	
Walkways intended to be used as roof access for inclined roofs for buildings	
Väsentliga egenskaper	Prestanda
Uttformning	Class 2 enl 6.1, Typ B enl 6.2
Statisk belastning enl 7.1	Uppfyller
Dynamisk belastning enl 7.2	Uppfyller
Reaktion vid brand enl 7.3	Klass A1
Beständighet mot korrosion enl. 5	Uppfyller

# Roof walkway with rail

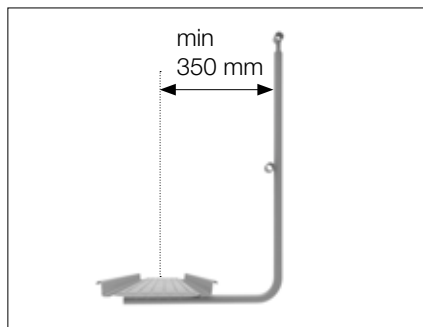
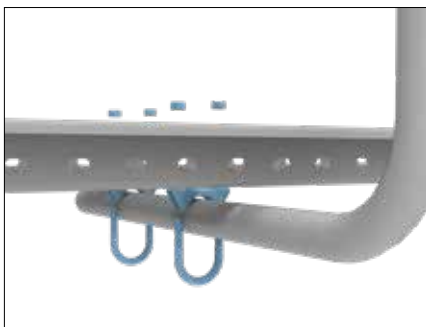
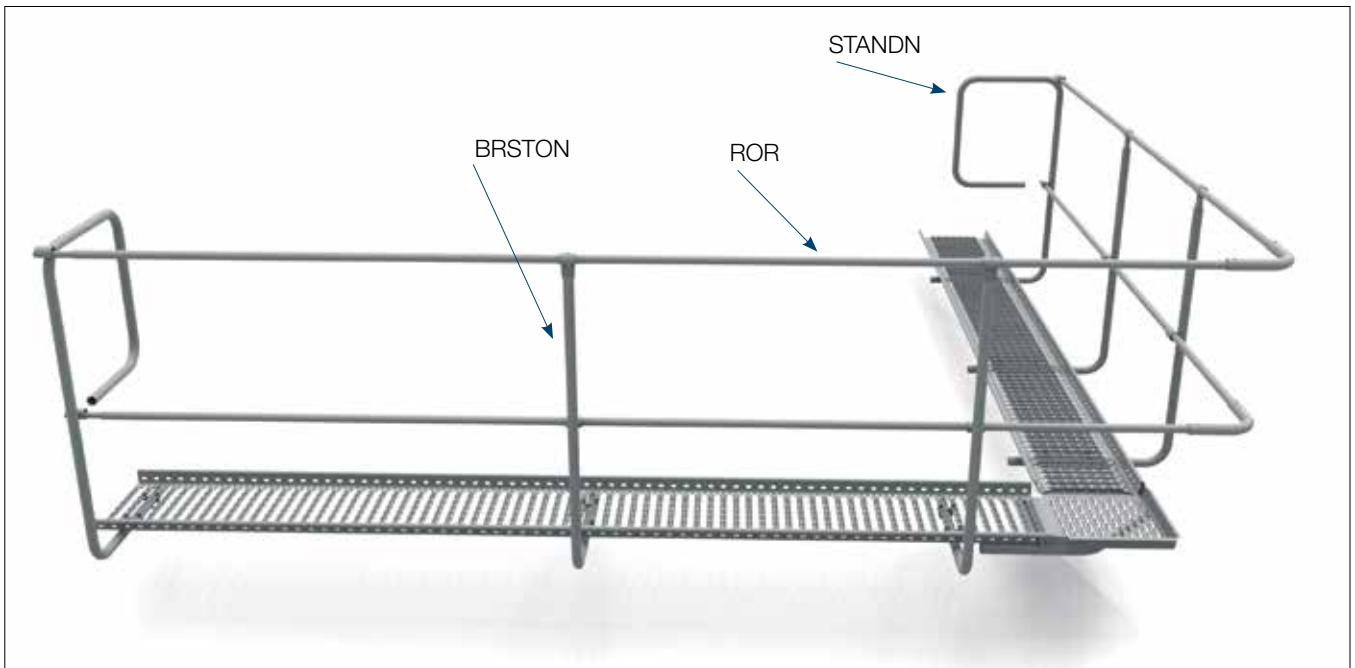

**NOTE:**

*The start and end walkway must be supported on at least two brackets.*



Install the BRSTON and STANDN rails with bracket, clamps, washer and nut from bolt set 8. Washer to be mounted under nut, fix the nut on the bracket, max. c-c 1,200 mm.

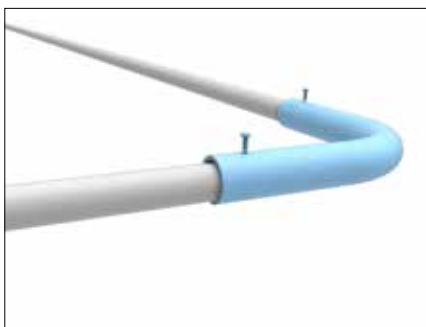

HRN for joints in corners.

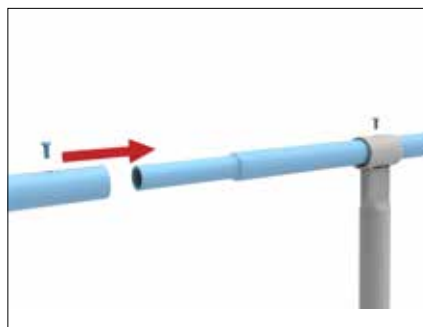

Fasten and/or joint ROR in STANDN or BRSTON. Fasten with a drill bit screw at each joint with ROR. Fasten STANDN och BRSTON with 2 drill bit screws from bolt set 8, one on the upperside and one in the middle.

# Roof ladder

## Installation on concrete tile with light underlay

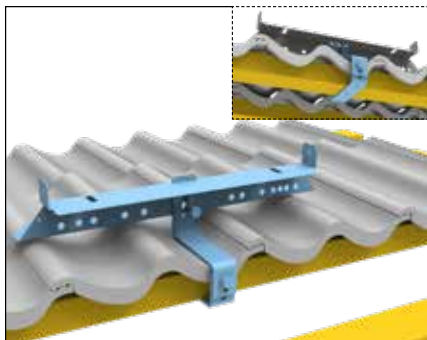

Fasten TSKP around the batten. Loosen the nut and adjust TSKP if needed. TSK is fastened on TSKP with 1 bolts and nuts from bolt set 37. The maximum distance between brackets is 1,5 m. At least three pairs of brackets must be used for each ladder length.

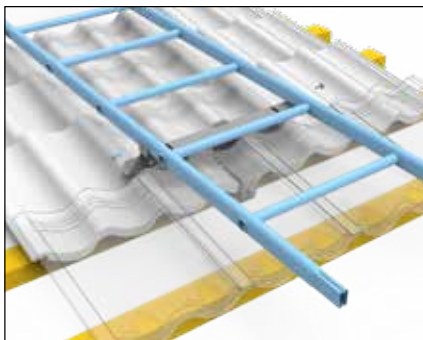

Fasten the ladder on TSK with 2 included drill bit screws.

## Installation on concrete tile on tongue-in-groove



Fasten TSKP in the underlay. The maximum distance between brackets is 1,5 m. At least three pairs of brackets must be used for each ladder length.



TSK is fastened on TSKP with bolts and nuts.



Fasten the ladder on TSK with 2 included drill bit screws.

## Installation requirements

- The max. overhang is 300 mm
- One alternative is to install a roof walkway if the maximum roof pitch is 15°.
- Bracket TSKFF should be used in combination with seam fastener FF on roofs with roof sheeting.
- When fastening on roofs with profiled steel sheet, TSK is used in combination with TSKIF.
- The bracket TSK is used for roofs with external insulation.
- Min. 45x70 batten for light underlay.

The ladder is to be used by one person including safety equipment (max 150kg)

It is possible to adjust the length of the ladder after your need, cut using a hacksaw and then repaint the surface.



21  
Lindab Profil AB  
Vistorpsvägen 56, 26971 Förslöv, Sverige  
Takstege NR 022020  
DoP nr 022020  
Anmält organ: 0402  
SS-EN 12951:2004 Permanently fixed roof ladder  
Roof access for inclined roofs for buildings C2-TB

Väsentliga egenskaper	Prestanda
Uttformning enl 5	Uppfyller
Statisk belastning enl 6	Uppfyller
Dynamisk belastning enl 6.3	Uppfyller
Reaktion vid brand enl 6.4	Klass A1
Beständighet mot korrosion enl.4	Uppfyller

# Roof ladder

## Installation on clay tile with light underlay

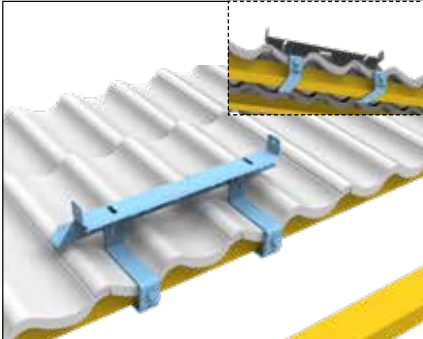

Fasten TSKP around the batten. Loosen the screw and adjust TSKP if needed. TSK is fastened on TSKP with 1 screw and nut from bolt set 37. The maximum distance between brackets is 1,5m. At least three pairs of brackets must be used for each ladder length.

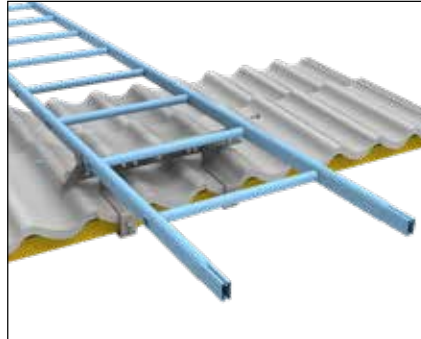

Fasten the ladder on TSK with 2 included drill bit screws.

## Installation on clay tile on tongue-in-groove



Fasten TSKP in the underlay. Loosen the nut and adjust TSKP. Fasten TSKP with 3 wood screws from bolt set 37. The maximum distance between brackets is 2 m. At least three pairs of brackets must be used for each ladder length.



TSK is fastened on TSKP with bolts and nuts.



Fasten the ladder on TSK with drill bit screws.

## Installation requirements

- The max. overhang is 300 mm
- One alternative is to install a roof walkway if the maximum roof pitch is 15°.
- Bracket TSKFF should be used in combination with seam fastener FF on roofs with roof sheeting.
- When fastening on roofs with profiled steel sheet, TSK is used in combination with TSKIF.
- The bracket TSK is used for roofs with external insulation.
- Min. 45x70 batten for light underlay.

The ladder is to be used by one person including safety equipment (max 150kg)

It is possible to adjust the length of the ladder after your need, cut using a hacksaw and then repaint the surface.

# CE

21

Lindab Profil AB

Vistorpsvägen 56, 26971 Förslöv, Sverige

Takstege NR 022020

DoP nr 022020

Anmält organ: 0402

SS-EN 12951:2004 Permanently fixed roof ladder

Roof access for inclined roofs for buildings C2-TB

Väsentliga egenskaper

Prestanda

Uttömning enl 5

Uppfyller

Statisk belastning enl 6

Uppfyller

Dynamisk belastning enl 6.3

Uppfyller

Reaktion vid brand enl 6.4

Klass A1

Beständighet mot korrosion enl.4

Uppfyller

# Roof ladder

## Installation on sandwich roof

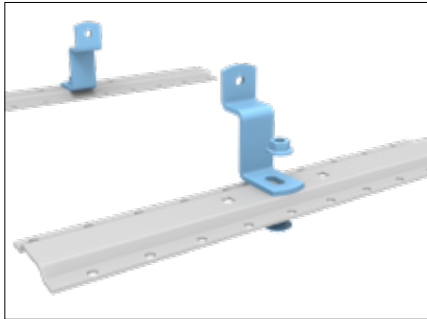

Install the bracket TSKL on SAWPLF. Use screws and nut from bolt set 11. The nuts are positioned on the upper side.

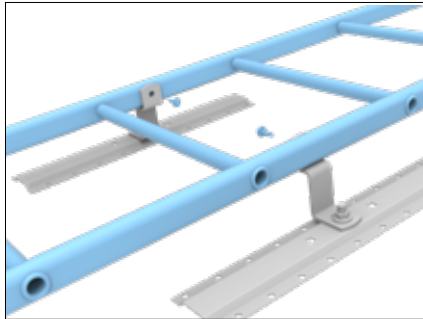

Mount two TSKL + SAWPLF on each side of the top of the ladder. Mount with accompanying drill bit screw.



Install the top of the ladder by fastening SAWPLF on the roof panel. Use the 8 accompanying point screws from bolt set 11. .

## Installation on flat roof

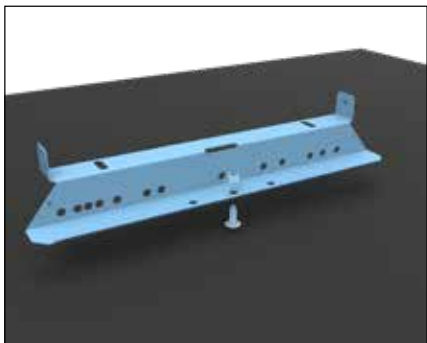

Fasten TSKL on the VIPP bolt. The maximum distance between brackets is 1,5 m. At least three pairs of brackets must be used for each ladder length.



Fasten the ladder on TSK with 2 drill bit screws from bolt set 36..

CE

21

Lindab Profil AB

Vistorpsvägen 56, 26971 Förslöv, Sverige

Takstege NR 022020

DoP nr 022020

Anmält organ: 0402

SS-EN 12951:2004 Permanently fixed roof ladder

Roof access for inclined roofs for buildings C2-TB

Väsentliga egenskaper	Prestanda
Uttömning enl 5	Uppfyller
Statisk belastning enl 6	Uppfyller
Dynamisk belastning enl 6.3	Uppfyller
Reaktion vid brand enl 6.4	Klass A1
Beständighet mot korrosion enl.4	Uppfyller

# Roof ladder

## Installation on standing seam long strip roofing or SRP25N

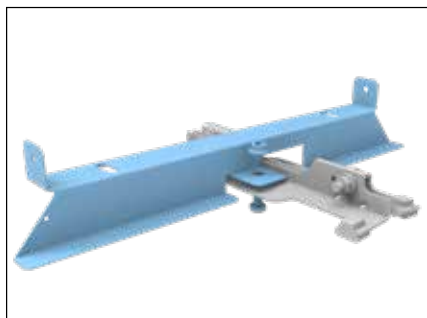

For standing seam long strip roofing, FF is used as a supporting bracket and TSKFF as a ladder bracket. FF is pre-mounted, fasten TSKFF with screw and nut from bolt set 36.

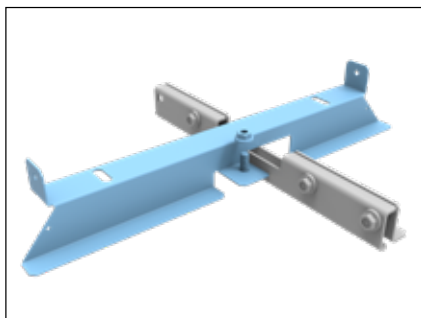

For SRP25, IFSRP is used as a supporting bracket and TSKFF as a ladder bracket. IFSRP is pre-mounted, fasten TSKFF with screw and nut from bolt set 36.

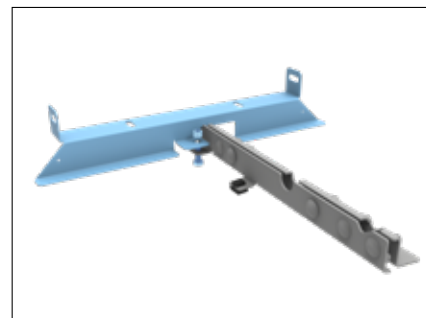

For SRP25N, IFSRPN is used as a supporting bracket and TSKFF as a ladder bracket. IFSRPN is pre-mounted, fasten TSKFF with screw and nut from bolt set 36.

## Installation on other steel sheet roofing

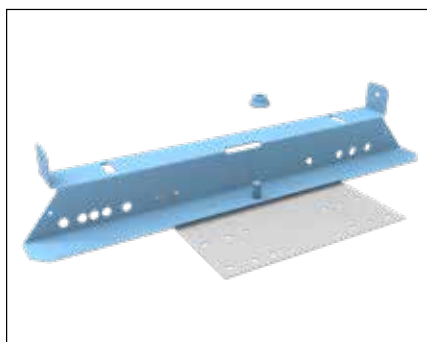

For roofs with trapezoidal corrugated steel sheet, high-profile sheet or sinusoidal corrugated sheet or the Lindab tile, TSKIF is used as a fastening plate under the TSK ladder bracket. Mount TSK on TSKIF with 1 screw and nut from bolt set 37.

# CE

21

Lindab Profil AB

Vistorpsvägen 56, 26971 Förslöv, Sverige

Takstege NR 022020

DoP nr 022020

Anmält organ: 0402

SS-EN 12951:2004 Permanently fixed roof ladder

Roof access for inclined roofs for buildings C2-TB

Väsentliga egenskaper

Prestanda

Utförning enl 5

Uppfyller

Statisk belastning enl 6

Uppfyller

Dynamisk belastning enl 6.3

Uppfyller

Reaktion vid brand enl 6.4

Klass A1

Beständighet mot korrosion enl.4

Uppfyller

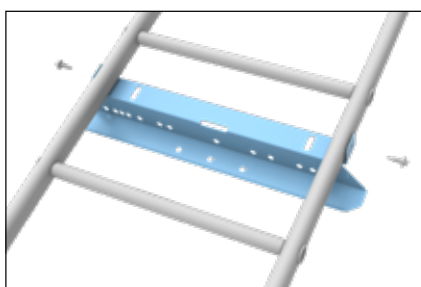
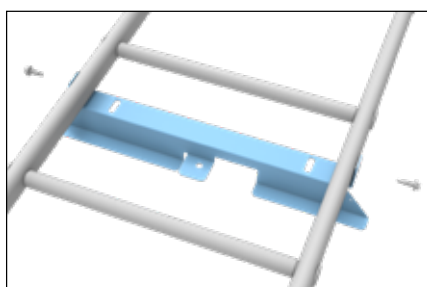

Fasten the TSK ladder on the TSK/TSKFF ladder bracket with 2 drill bit screws from bolt set 36. The maximum distance between brackets is 1,5 m. At least three pairs of brackets must be used for each ladder length.

# Roof ladder

## Joining of ladders

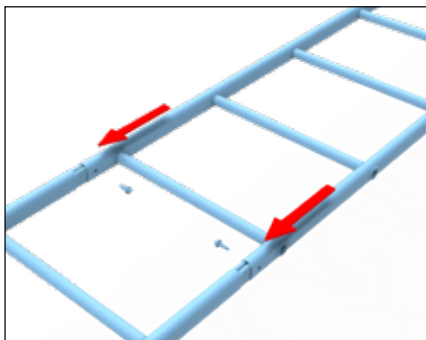

The ladder is joined by guiding the crimped end into the upper ladder. Fasten them together with 2 accompanied drill bit screw.

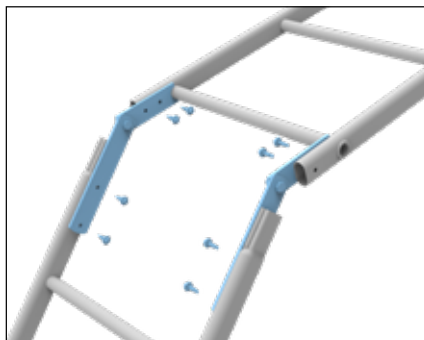

The TSSV joining kit is used for discontinuous roofs. Mount TSSV with 8 accompanied drill bit screws.

## Rail for roof ladder. Roof pitch 0-45° (TSRH)

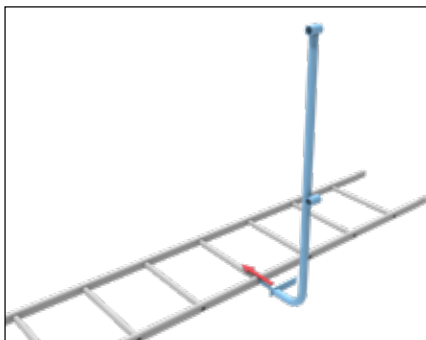

Guide the rail post TSRH through the rungs of the ladder. The maximum distance between guard rail posts is 2m.



Fix through the roof side with drill bit screw.

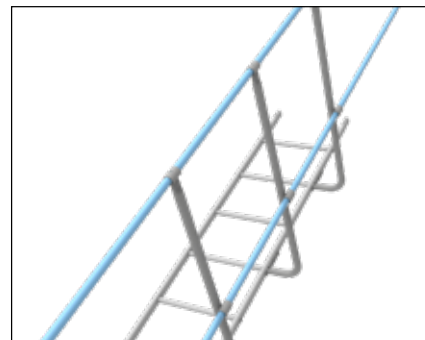

Thread ROR through the sleeves in the top and middle, fasten with accompanied drill bit screw.

# CE

21

Lindab Profil AB

Vistorpsvägen 56, 26971 Förslöv, Sverige

Takstege NR 022020

DoP nr 022020

Anmält organ: 0402

SS-EN 12951:2004 Permanently fixed roof ladder

Roof access for inclined roofs for buildings C2-TB

Väsentliga egenskaper	Prestanda
Utförning enl 5	Uppfyller
Statisk belastning enl 6	Uppfyller
Dynamisk belastning enl 6.3	Uppfyller
Reaktion vid brand enl 6.4	Klass A1
Beständighet mot korrosion enl.4	Uppfyller

# Roof ladder

## Rail for roof ladder. Roof pitch 25-45° (TSRL)

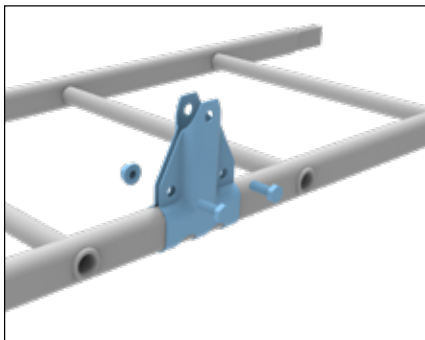

Fix the TSRL fastener on the side of the ladder with two accompanied screws and nuts. Max. distance of 2m between fastening points.

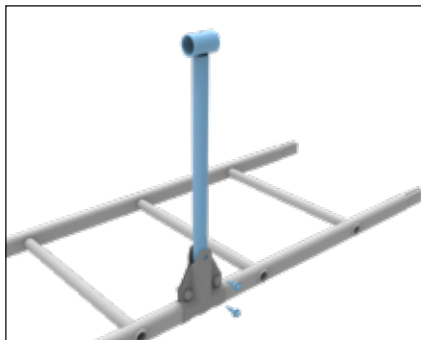

Fix through the roof side with 2 accompanied drill bit screws.



Thread the tube through the sleeves in the top and middle, fasten with 2 accompanied drill bit screws in each sleeve.

## TSST steps for roof ladder

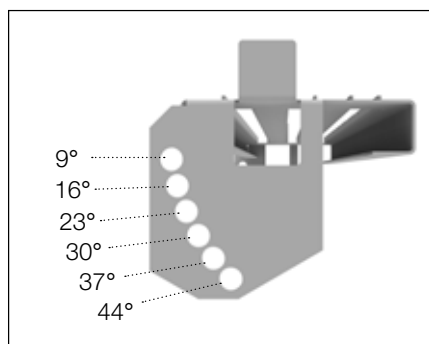

Measure the roof pitch and determine which hole is suitable for the roof pitch.

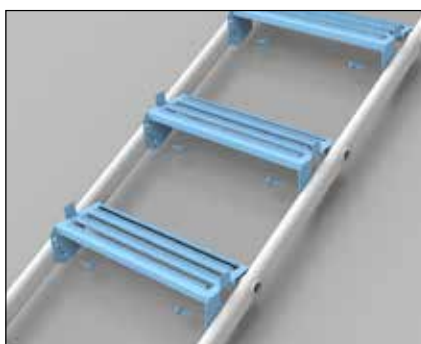

Hook TSST around the rung and fasten with 2 accompanied drill bit screws.

Length of ladder	No. of rungs
1,500	5
1,800	6
2,400	8

# CE

21

Lindab Profil AB

Vistorpsvägen 56, 26971 Förslöv, Sverige

Takstege NR 022020

DoP nr 022020

Anmält organ: 0402

SS-EN 12951:2004 Permanently fixed roof ladder

Roof access for inclined roofs for buildings C2-TB

Väsentliga egenskaper

Prestanda

Utformning enl 5

Uppfyller

Statisk belastning enl 6

Uppfyller

Dynamisk belastning enl 6.3

Uppfyller

Reaktion vid brand enl 6.4

Klass A1

Beständighet mot korrosion enl.4

Uppfyller

# Installation of wire system - ridge rail

## Installation requirements

- The support fasteners are installed at a maximum distance of 10m for assembly as fall protection.
- With installation as support for work, the support fasteners are installed at a maximum distance of 2.5m.



Mount the WFANDL start and end fastener at the beginning and end of the wire strand. The assembly is carried out with 2 U-brackets and nuts and a retaining plate from bolt set 8. .



Mount the WFSTL support fasteners in the same manner with c/c distance according to the installation conditions. he assembly is carried out with 2 U-brackets and nuts and a retaining plate from bolt set 8. .



Install WSLOP wire runner for runners on WFSTL wire support. Use the accompanying bolt and nut.

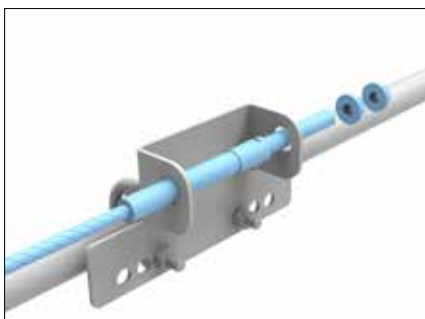

Thread one end of the wire through start/end fastener WFANDL. Fix with disc and M12 double nut, premounted on the wire.



Thread the wire through all WSLOP wire supports to the end of the wire assembly.



Thread the desired number of WLOPL runners over the other end of the wire.

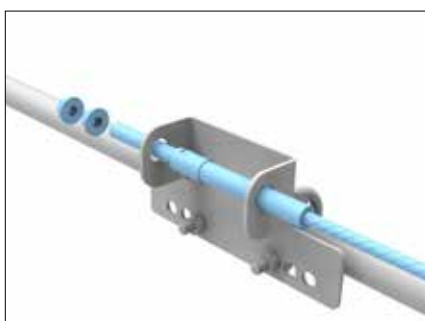

Thread the wire end through WFANDL end fastener and fix with disc and M12 double nut. The wire should only be tightened til it is stretched.

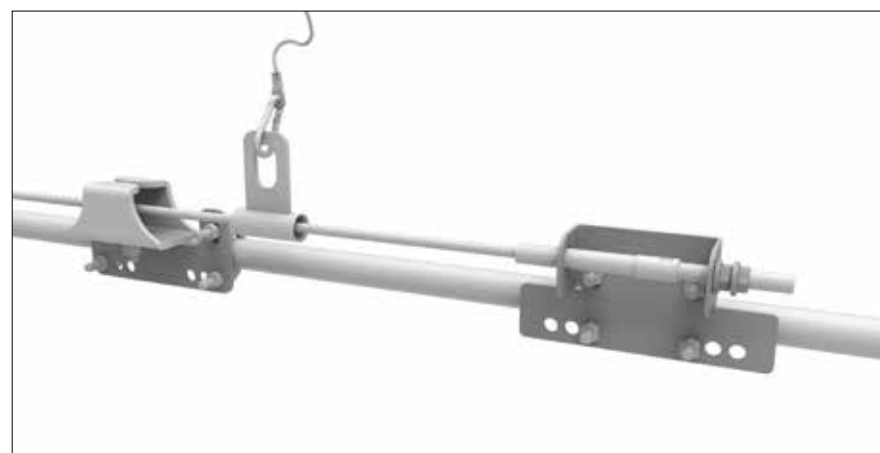

# Wire system

- *walkway parallel to the ridge*

## Installation requirements

- The support fasteners are installed at a maximum distance of 10m for assembly as fall protection.
- With installation as support for work, the support fasteners are installed at a maximum distance of 2.5m.



Mount the WFANDL start and end fastener at the beginning and end of the wire strand. Installation takes place with the 2 bolts and nuts from bolt set 32..



Install WSLOP wire support for runners on the WFSTL wire support. Use the accompanying bolt and nut.

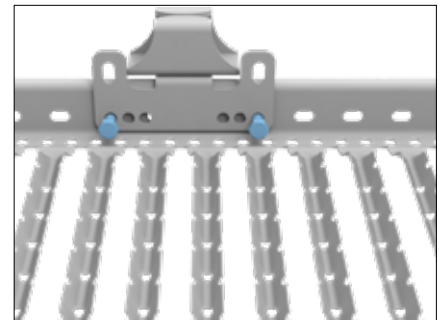

Mount the WFSTL support fasteners in the same manner with c/c distance according to the installation conditions.

Mount with screw and nut from bolt set 32.

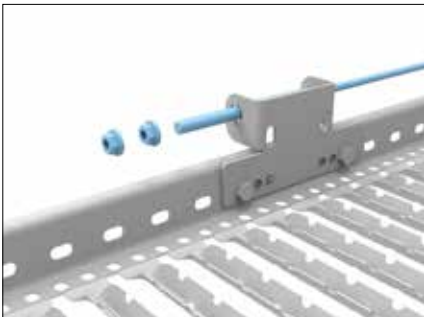

Thread one end of the wire start/end fastener WFANDL. Fix with disc and M12 double nut, premounted on wiren.

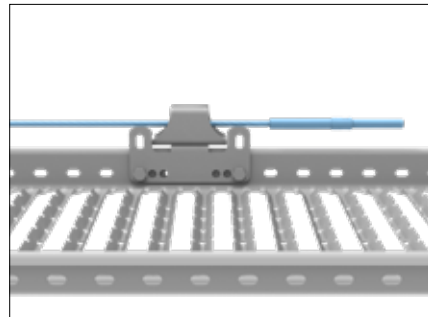

Thread the wire through all WSLOP wire supports to the end of the wire assembly.

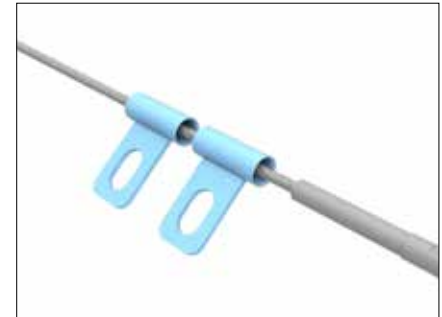

Thread the desired number of WLOPL runners over the other end of the wire.

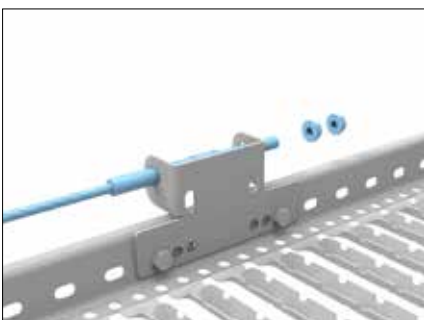

Guide wire end through WFANDL end fastener and fix with disc and M12 double nut, premounted on the wire. The wire should only be tightened til it is stretched.

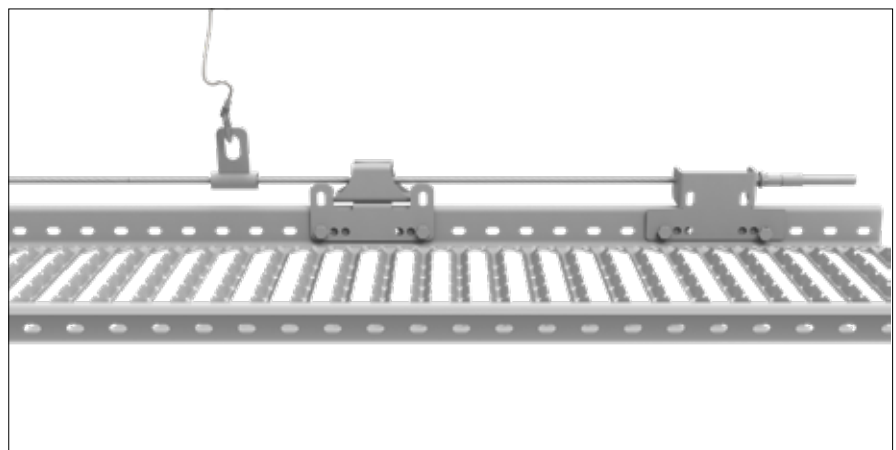

# Wire system

- walkway vertically towards the ridge

## Installation requirements

- Approved for installation on maximum 15° roof pitch.
- The support fasteners are installed at a maximum distance of 2,5m
- Always install a support fastener 1m from eaves.



Mount the WFANDL start and end fastener at the beginning and end of the wire strand. Installation takes place with the 2 bolts and nuts from bolt set 32..

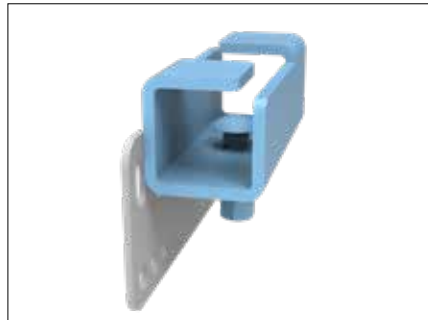

Install WSLOPS wire support for runners on the WFSTL wire support. Use the accompanying bolt and nut.

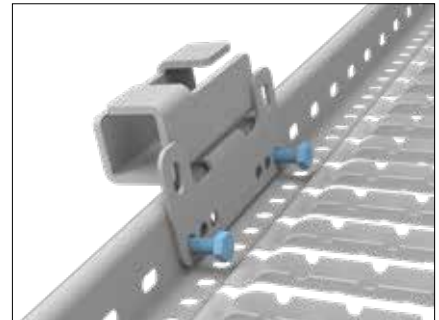

Mount the WFSTL support fasteners in the same manner with c/c distance according to the installation conditions. Mount with screw and nut from bolt set 32.

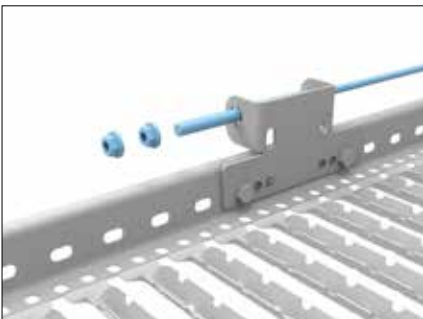

Thread one end of the wire start/end fastener WFANDL. Fix with disc and M12 double nut, premounted on wiren.

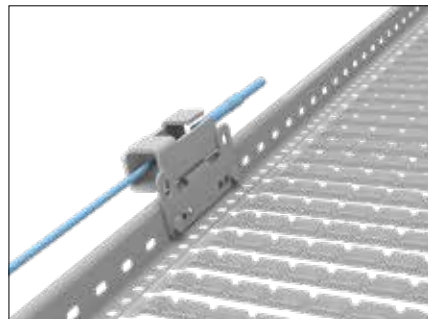

Thread the wire through all WSLOPS wire supports to the end of the wire assembly.

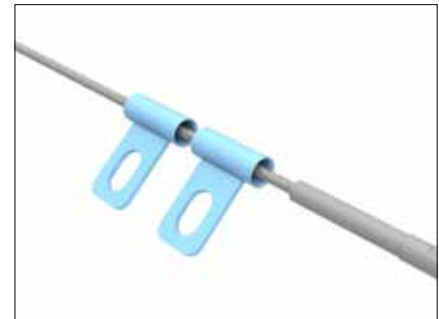

Thread the desired number of WLOPL runners over the other end of the wire.

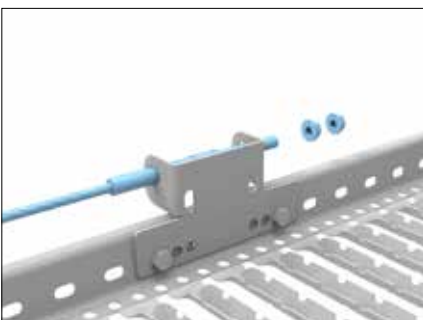

Guide wire end through WFANDL end fastener and fix with disc and M12 double nut, premounted on the wire. The wire should only be tightened til it is stretched.

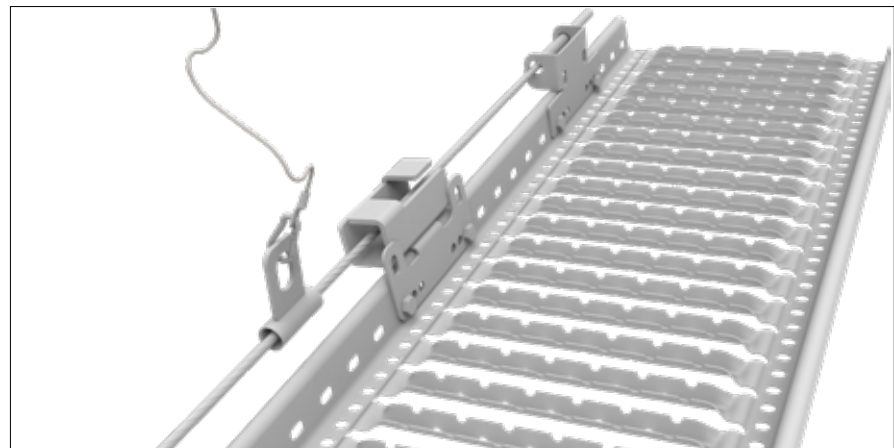

# Wiresystem - roof ladder



Mount the WENDTVS start/end fastener at the beginning and end of the wire strand. Installation takes place with 4 accompanying screw and nut according to illustration.

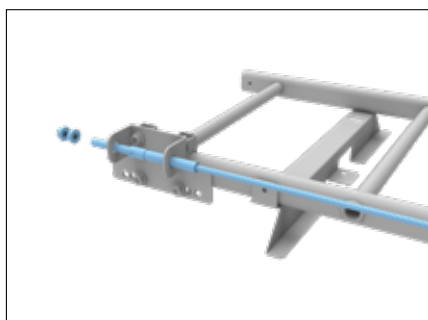

Thread one end of the wire start/end fastener WENDTVS. Fix with disc and M12 double nut, premounted on wiren.

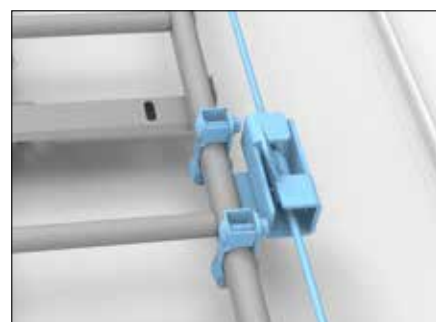

Install the correct number of wire support WFSTLTVS according to your roof pitch (see installation requirements). Install against roof ladder with 4 accompanying bolt and nut according to illustration. the wire support is fastened with 1 screw and nut from underneath.

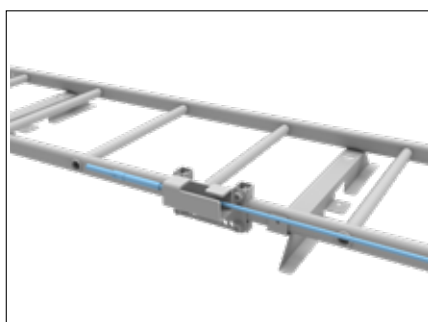

Thread the wire through all WFSTLTVS wire supports to the end of the wire assembly.

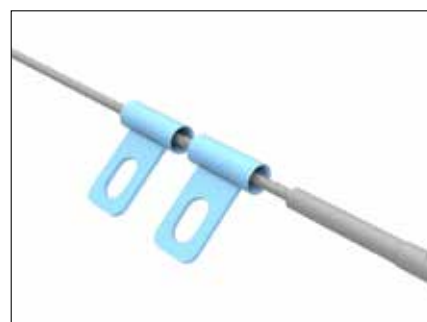

Thread the desired number of WLOPL runners over the other end of the wire.

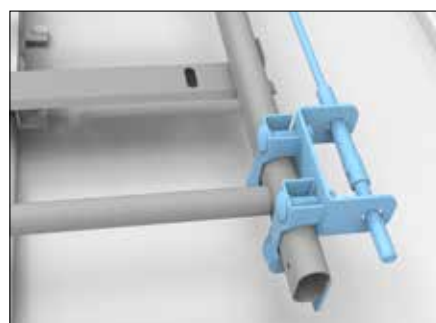

Mount the WENDTVS start/end fastener at the beginning and end of the wire strand. Installation takes place with 4 accompanying screw and nut according to illustration.

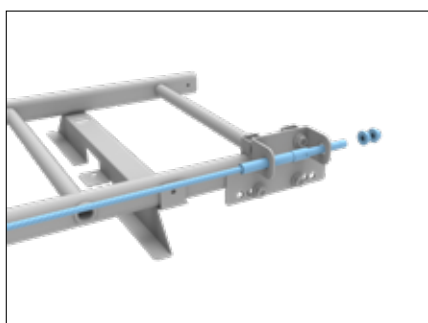

Guide wire end through WENDTVS start/end fastener and fix with disc and M12 double nut. The wire should only be tightened til it is stretched.



## Installation requirements

- Roof pitch 0-15° - two end fasteners on each wire, wire support with 2500mm gap and wire support at 1000mm distance from eaves.
- Roof pitch 16-45° - two end fasteners on each wire, wire support with 1500mm gap and wire support at 1000mm distance from eaves.
- Roof pitch 46-55° - two end fasteners on each wire, wire support with 1000mm gap.
- Roof pitch 56°-75° - two end fasteners on each wire, wire support with 300mm gap

Maximum roof pitch for wire system on roof ladder 75°

# Wire system - *façade ladder*

## Installation requirements

- The package VSWF includes everything needed for wire systems for façade ladders (façade height up to 8 m).
- Mount the accompanying instruction sign on the wall or similar directly adjacent to the ascension point.



Mount the upper wire fastener (VSWFO) at the top of the right or left side of the façade ladder with the two accompanying screws and nuts.

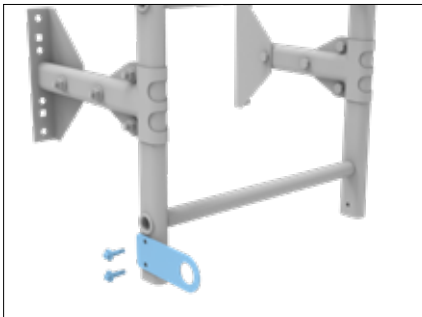

Mount the lower wire fastener (VSWFU) at the bottom of the façade ladder on the same side with the accompanying screw.



Tie the tension rope to the small carabiner hook on the wire pulley.



Fasten the the wire pulley's carabiner hook to the upper fastener VSWFO and tie the tensin rope the lower fastener VSWFU.

# Anchorage point

## Installation on standing seam long strip roofing or SRP25N



Mount LLFDF around the steel panel seam. Ensure that the seam fastener's heels rests on the roof. Tighten the bolts to 20 Nm. Anchorage point LLFDF to be mounted on aluminium or copper roofs must be supplemented with I insulation profile IPLL.

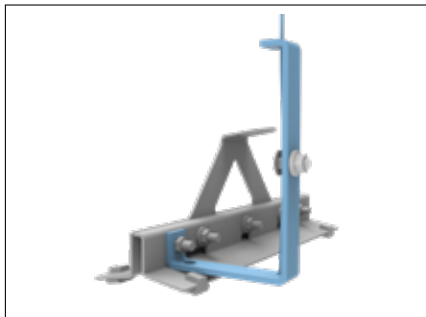

When mounting a snow depth indicator, attach it to LLFDF by loosen the premounted nut and thread it over the screw, then tighten the nut again.

### Installation requirements

- Anchorage point may only be used by one person at a time.
- Anchorage point may only be used as single attachment point for roofs with roof pitch  $<6^\circ$ .

## Installation on felt roofing

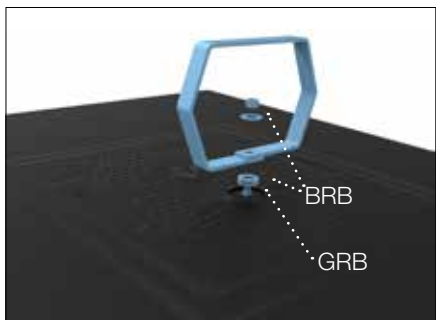

Mount LLF150 towards the roof surface and chosen fastening plate. Apply in the following order: rubber disc GRB, disc BRB, LLF150, disc BRB and finally a nut. Use bolt set 27.

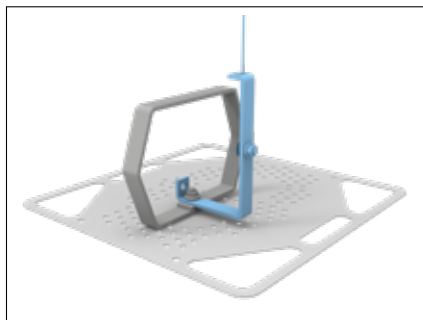

When mounting a snow depth indicator, attach it to LLF150 by loosen the premounted nut and thread it over the screw, then tighten the nut again.

## Installation on trapezoidal profile 115



First mount LLF on IF115 according to illustration. Fasten with 2 screws and nut from bolt set 31.

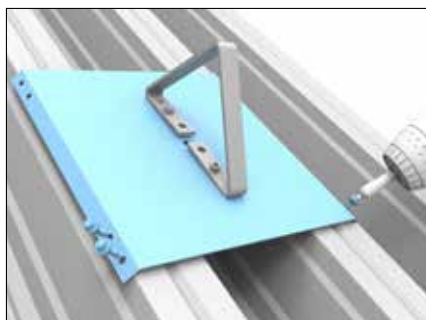

Position IF115 on a profile top on the plate at least 200 mm from the edge of the plate. If steel sheet with maximum 0,9mm thickness is used, mount with 8 point screws from bolt set 31. Steel sheet 1,0mm or more use 8 drill bit screws from bolt set 31.

# Anchorage point

## Installation on trapezoidal profile roofing



If LLF is to be used (anchorage point), first mount it on IF20, IF35, IF45 according to illustration. Use 2 screws and nut from bolt set 23 to fasten.

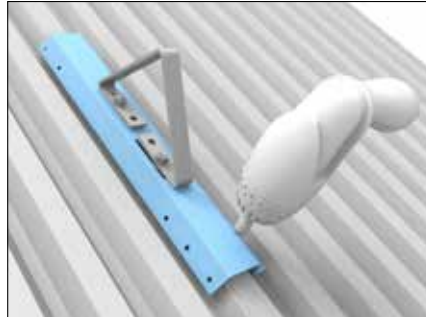

Position IF20, IF35, IF45 on a profile top on the plate at least 200 mm from the edge of the plate. Fasten with 8 screws from bolt set 23.

### Installation requirements

- Anchorage point may only be used by one person at a time.
- Anchorage point may only be used as single attachment point for roofs with roof pitch  $<6^\circ$ .

## Installation on sinusoidal profile roofing

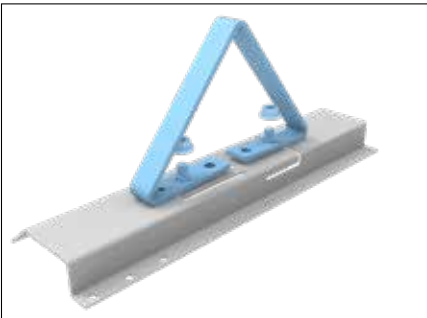

Mount LLF on IFSIN with 2 screws and nut from bolt set 29, fasten IFSIN against the roof profile with 10 screws from bolt set 29.

## Installation on steel sheet LPP20

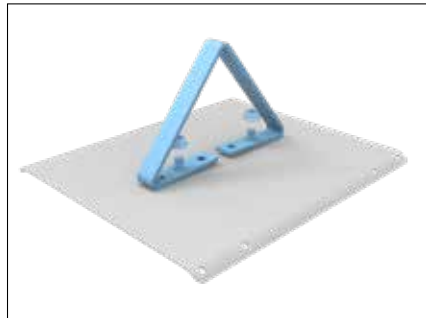

Mount LLF on IFLPP with 2 screws and nut from bolt set 23, fasten IFLPP against the roof profile with 8 drill bit screws from bolt set 23.

## Installation with pivot bolt

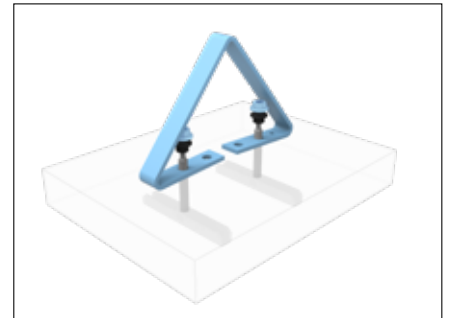

Mount LLF with 2 pivot bolts, attach the bracket to the screws and tighten the bolts to 35-50 Nm.

## Installation of snow depth indicator

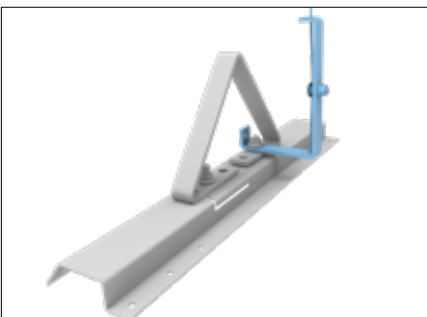

When mounting a snow depth indicator, attach it to LLF by loosen the nut and threading it over the screw, then tighten the nut again.





Most of us spend the majority of our time indoors. Indoor climate is crucial to how we feel, how productive we are and if we stay healthy.

We at Lindab have therefore made it our most important objective to contribute to an indoor climate that improves people's lives. We do this by developing energy-efficient ventilation solutions and durable building products. We also aim to contribute to a better climate for our planet by working in a way that is sustainable for both people and the environment.

[Lindab | For a better climate](#)