

# Lindab **EKOSI Damper with airflow meter**

Installation instruction

# Damper with airflow meter

EKOSI

## Assembly

Mount the dampers according to “Assembly Instructions Lindab Safe” to meet with the requirements for tightness class C (ATC3).

Consider required straight distance after or before disturbance, as mentioned on the card attached to the measurement nozzles, to obtain accurate airflow measurement.

The damper may not be loaded with weight from connected ducts, specially when assembled vertically.

## Measurement accuracy

If the velocity profile is asymmetric, the measurement values can differ from the ideal values. For this reason, the airflow meter should never be located right up to any airflow disturbance.

The method error in the table will differ, depending on the distance to the air airflow disturbance.

If the damper is installed under ideal conditions, a maximum air airflow deviation of  $\pm 5\%$  can be expected.

The damper complies with airtightness class C (ATC3) in accordance with EN 1751.

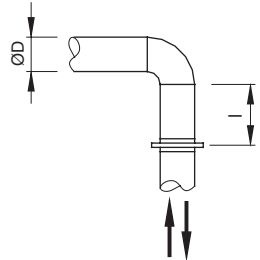
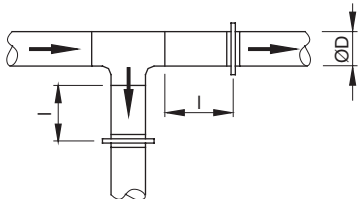
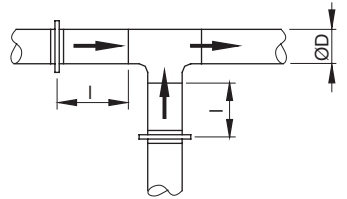
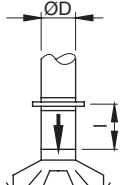
l = straight distance before and after disturbances	Method error $\pm 5\%$
	$l \geq 1 \text{ } \varnothing D$
	$l \geq 2 \text{ } \varnothing D$
	$l \geq 2 \text{ } \varnothing D$
	$l \geq 2 \text{ } \varnothing D$

# Damper with airflow meter

# EKOSI

## Balancing

- Connect the measuring hoses to the damper measuring nozzles.
- Adjust the desired restriction using a ring spanner or a screwdriver. Note the k-factor.
- Read the differential pressure  $\Delta p_m$
- Use a graph or the formula  $q = k \cdot \sqrt{\Delta p_m}$  to calculate the air airflow.
- Disconnect the hoses and plug the nozzles.

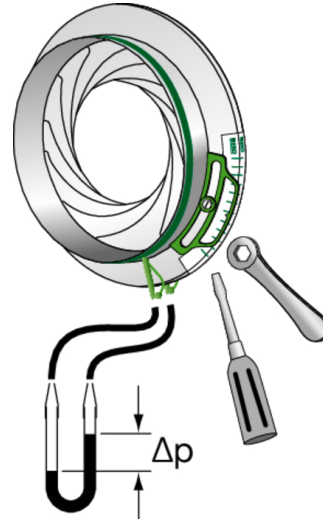

Ød	Ring key
80-160	8
250-315	10
400-630	15
800	22

## Maintenance

The product normally doesn't require any maintenance.

## Cleaning

*By fully open the damper, one get access to the duct.*

When cleaning the duct, make a note of the damper's position before it opens fully. Reset the damper setting afterwards.

# Damper with airflow meter

EKOSI

## Pressure loss graphs with noise generation for dimensioning

The dimensioning graphs show the pressure loss over the damper with airflow meter,  $\Delta p_t$ . They should be used to determine the pressure loss and to provide information about sound power levels at different settings.

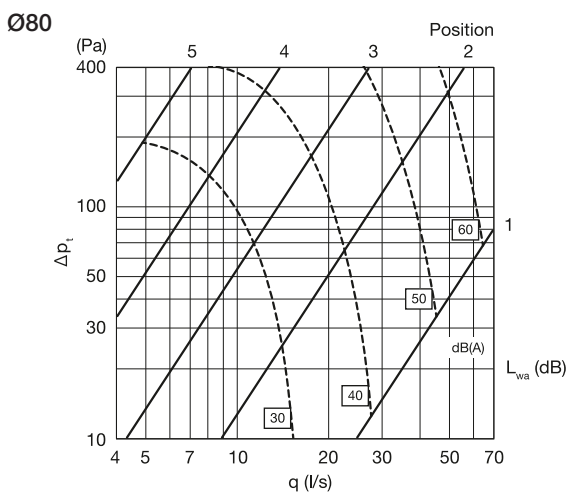
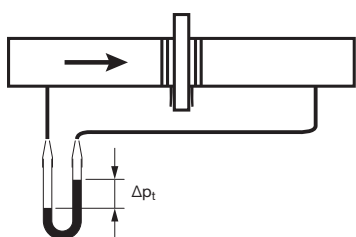

## Airflow graphs for balancing

The balancing graphs show the airflow as a function of the measured pressure,  $\Delta p_m$ . These graphs should be used to balance the system.

The balancing graphs show the airflow,  $q$ , as a function of the measured pressure,  $\Delta p_m$ , in the measure nozzles.

$$q = k \cdot \sqrt{\Delta p_m} \text{ (l/s)}$$

The formula is only accurate for air with the density 1,2 kg/m<sup>3</sup>. For air with other density, ( $\rho_{other}$ ), the airflow, ( $q_{other}$ ), is given according to the formula.

$$q_{other} = q_{equation} \times \sqrt{\frac{1,2}{\rho_{other}}}$$

k-factors can be found on the product label or in the Lindab calculation app, Vent Tools.

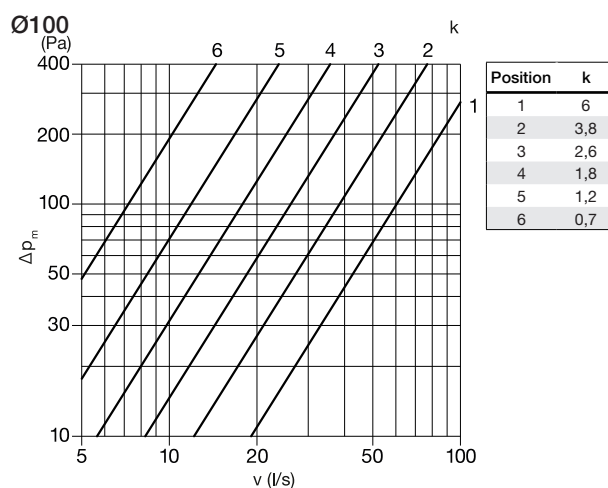
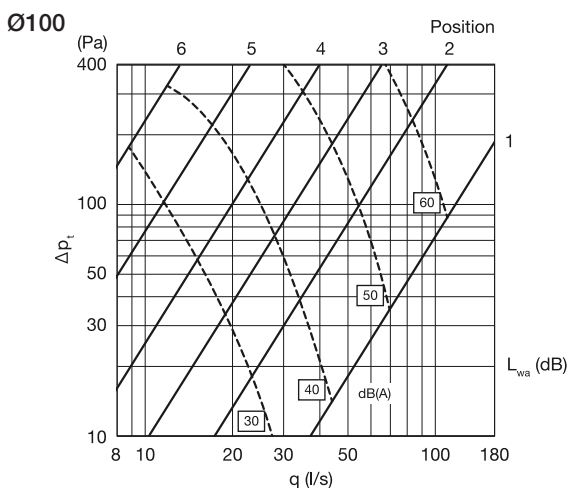
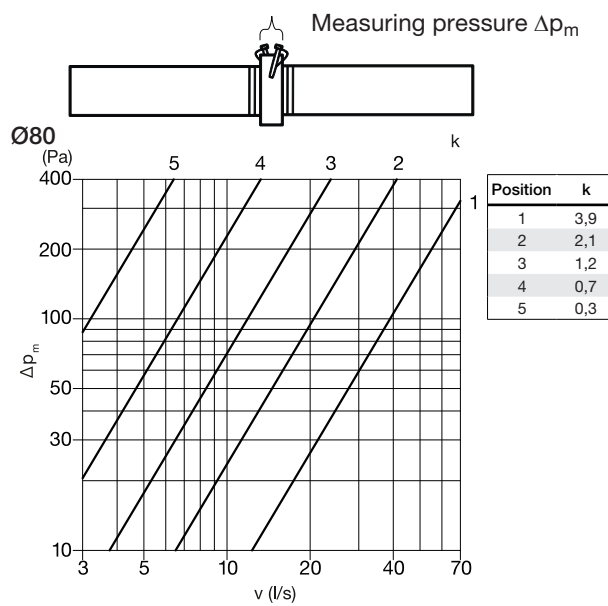

# Damper with airflow meter

# EKOSI

## Pressure loss graphs with noise generation for dimensioning

## Airflow graphs for balancing

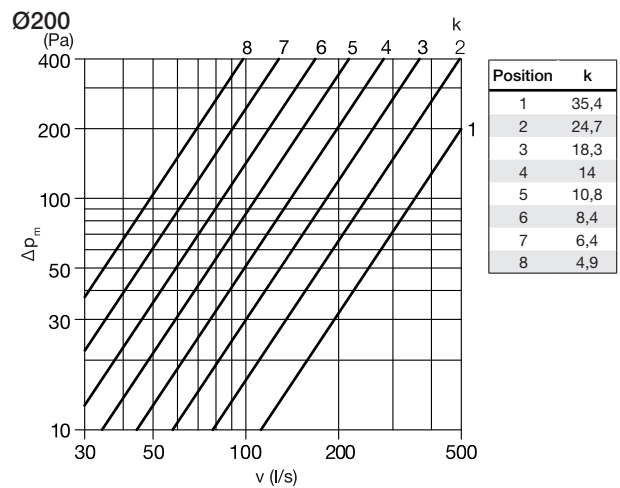
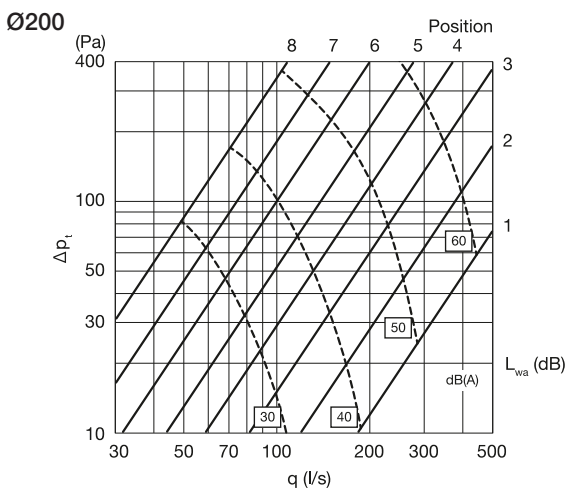
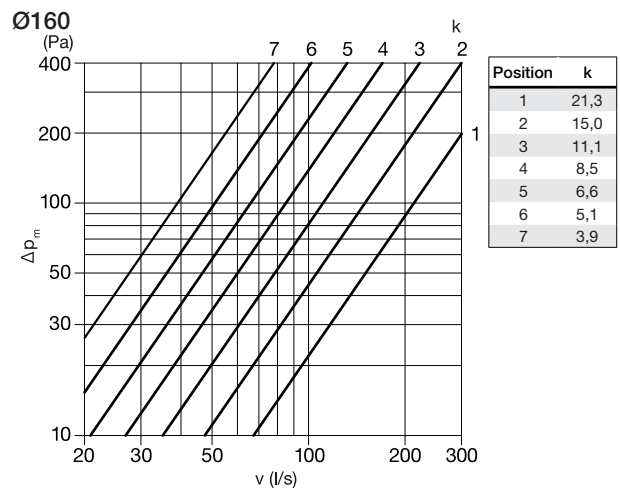
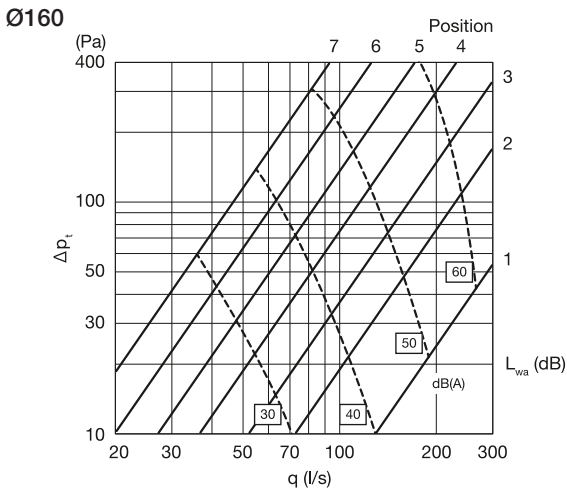
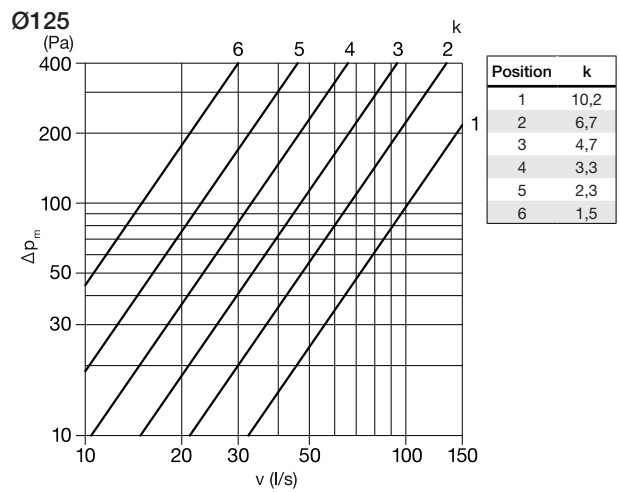
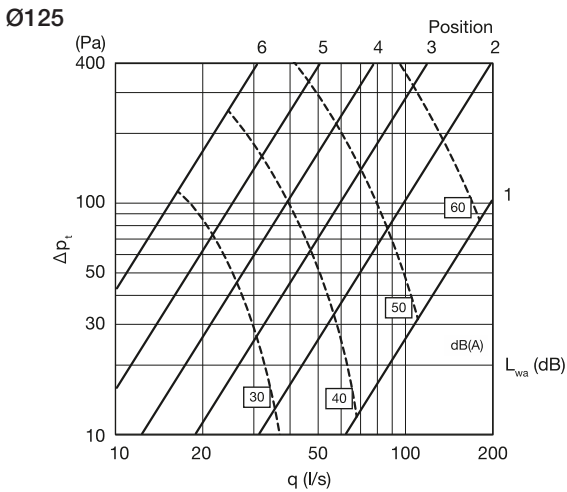

# Damper with airflow meter

EKOSI

## Pressure loss graphs with noise generation for dimensioning

## Airflow graphs for balancing

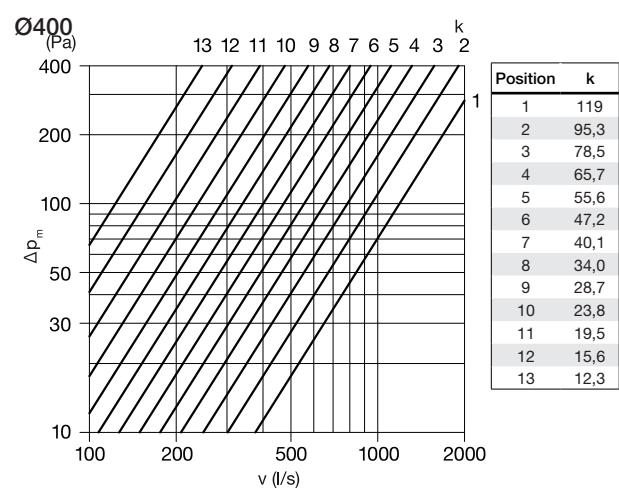
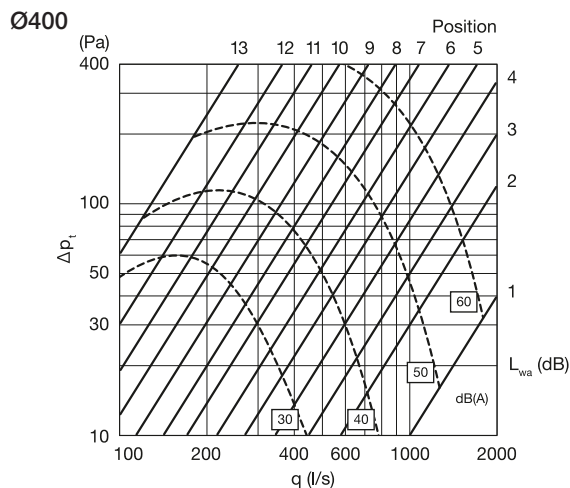
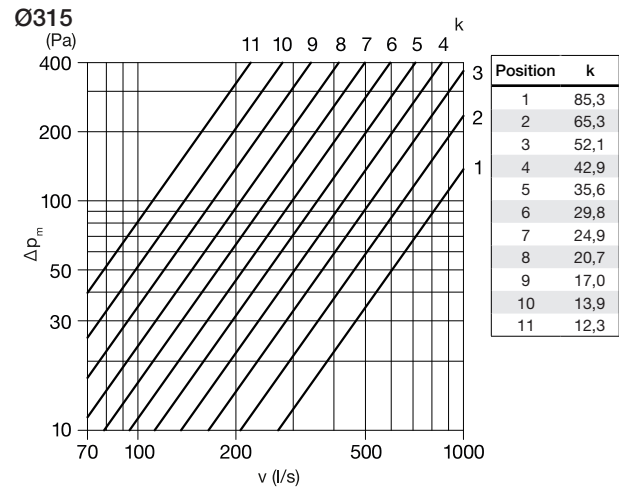
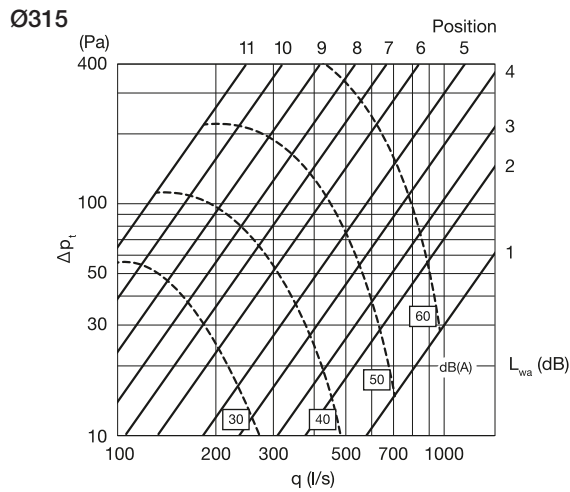
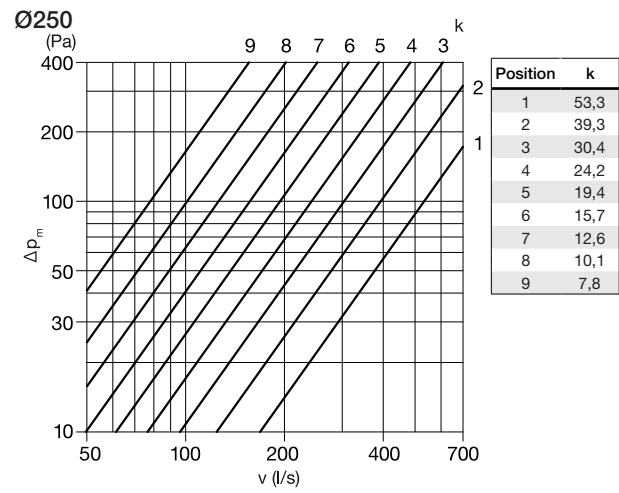
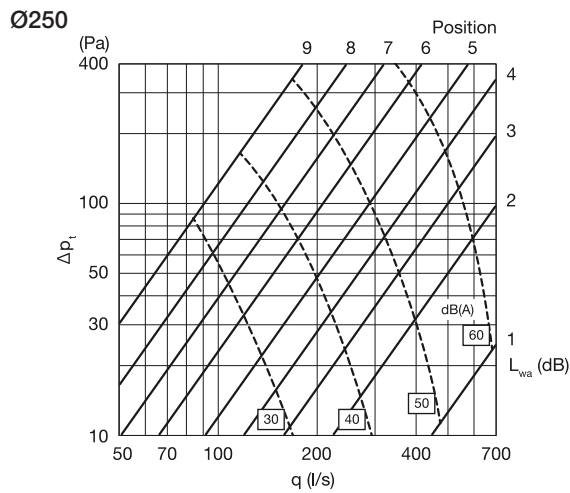

# Damper with airflow meter

# EKOSI

## Pressure loss graphs with noise generation for dimensioning

## Airflow graphs for balancing

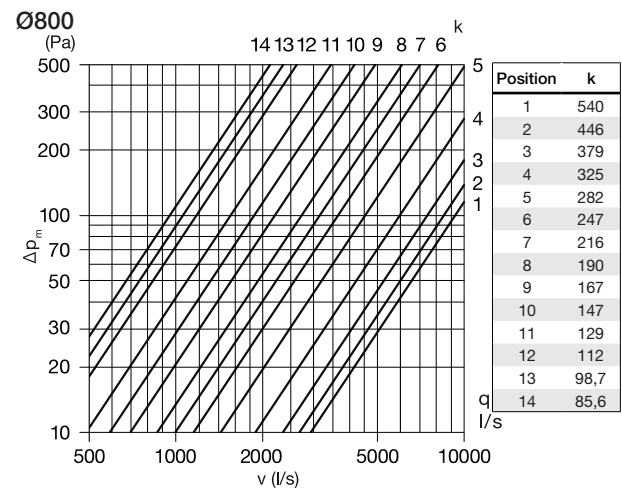
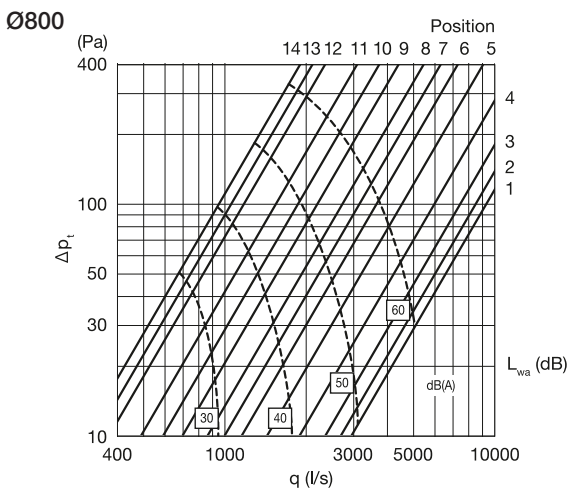
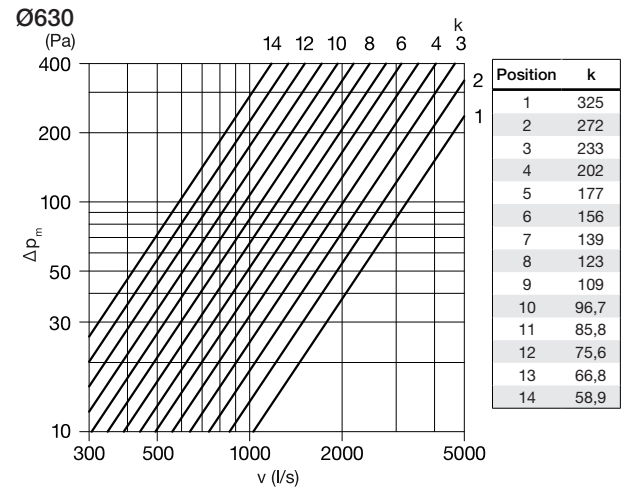
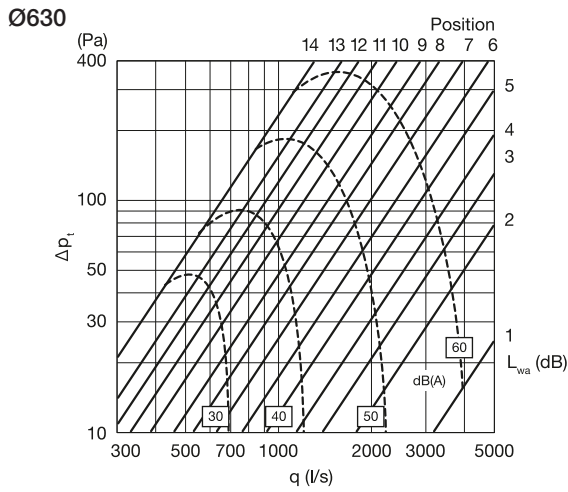
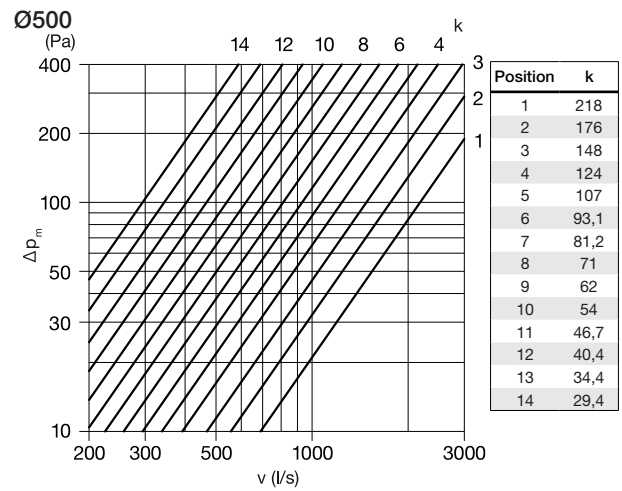
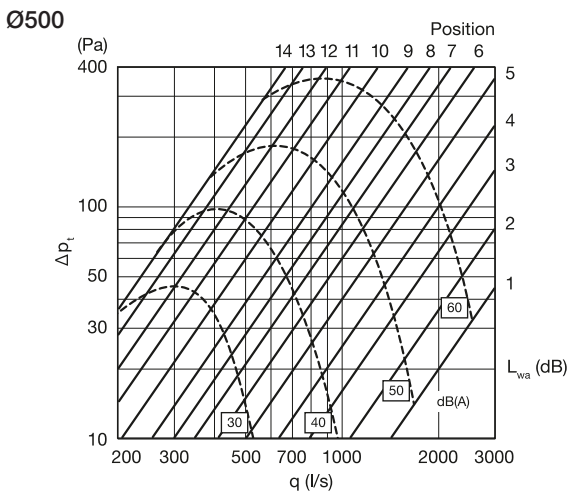



Most of us spend the majority of our time indoors. Indoor climate is crucial to how we feel, how productive we are and if we stay healthy.

We at Lindab have therefore made it our most important objective to contribute to an indoor climate that improves people's lives. We do this by developing energy-efficient ventilation solutions and durable building products. We also aim to contribute to a better climate for our planet by working in a way that is sustainable for both people and the environment.

[Lindab | For a better climate](#)